

Panasonic®

Wide Screen TV Operating Instructions

Model No. **CT-30WX50**

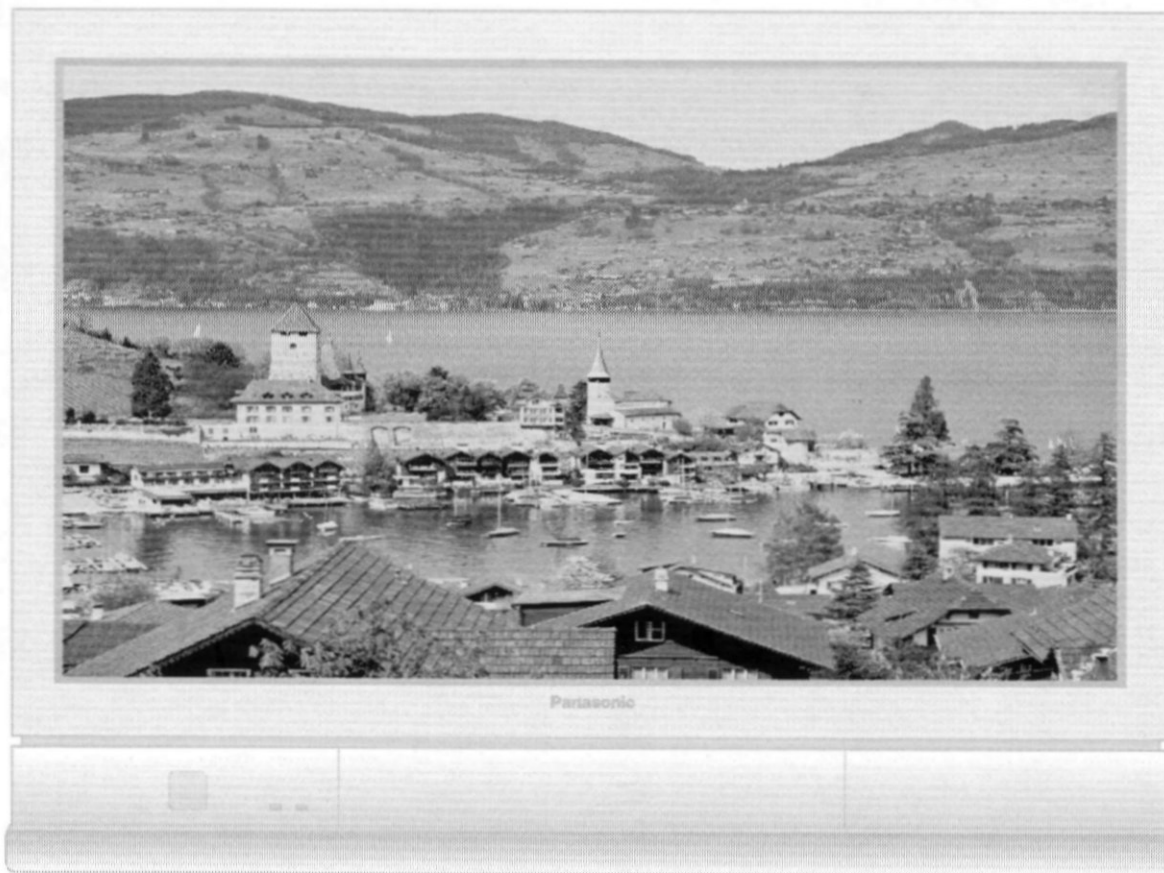

For assistance, please call : 1-888-VIEW-PTV(843-9788)

or send e-mail to : consumerproducts@panasonic.com

or visit us at www.panasonic.com

(U.S.A)



For assistance, please call : 787-750-4300

(Puerto Rico)

English

TQBC0278-1

Important Safety Instructions

	WARNING RISK OF ELECTRIC SHOCK DO NOT OPEN	
WARNING: To reduce the risk of electric shock do not remove cover or back. No user-serviceable parts inside. Refer servicing to qualified service personnel.		



The lightning flash with arrow-head within a triangle is intended to tell the user that parts inside the product are a risk of electric shock to persons.



The exclamation point within a triangle is intended to tell the user that important operating and servicing instructions are in the papers with the appliance.

WARNING: To reduce the risk of fire or electric shock, do not expose this apparatus to rain or moisture. Do not place containers with water (flower vase, cups, cosmetics, etc.) above the set. (including on shelves above, etc.)

WARNING: 1) To prevent electric shock, do not remove cover. No user serviceable parts inside. Refer servicing to qualified service personnel.
2) Do not remove the grounding pin on the power plug. This apparatus is equipped with a three pin grounding-type power plug. This plug will only fit a grounding-type power outlet. This is a safety feature. If you are unable to insert the plug into the outlet, contact an electrician.
Do not defeat the purpose of the grounding plug.

Important Safety Instructions

- 1) Read these instructions
All the safety and operating instructions should be read before the appliance is operated
- 2) Keep these instructions
The safety and operating instructions should be retained for future reference
- 3) Heed all warnings
All warnings on the appliance and in the operating instructions should be adhered to
- 4) Follow all instructions
All operating and use instructions should be followed
- 5) Do not use this apparatus near water
For example, near a bathtub, wash bowl, kitchen sink, or laundry tube, in a wet basement, or near a swimming pool, and the like
- 6) Clean only with dry cloth
Do not use liquid cleaners or aerosol cleaners Use a dry cloth for cleaning
- 7) Do not block any ventilation openings Install in accordance with the manufacture's instructions
Slots and Openings in the cabinet are provided for ventilation and to ensure reliable operation of the product and to protect it from overheating The openings should never be blocked by placing the product on a bed, sofa, rug, or other similar surface
- 8) Do not install near any heat sources such as radiators, heat registers, stoves, or other apparatus (including amplifiers) that produce heat
This product should not be placed in a built-in installation such as a bookcase or rack unless proper ventilation is provided or the manufacturer's instructions have been adhered to
- 9) Do not defeat the safety purpose of the polarized or grounding-type plug A polarized plug has two blades with one wider than the other A grounding type plug has two blades and a third grounding prong The wide blade or the third prong are provided for your safety If the provided plug does not fit into your outlet, consult an electrician for replacement of the obsolete outlet
- 10) Protect the power cord from being walked on or pinched particularly at plugs, convenience receptacles, and the point where they exit from the apparatus
- 11) Only use attachments / accessories specified by the manufacturer
- 12) Use only with the cart, stand, tripod, bracket, or table specified by the manufacturer, or sold with the apparatus When a cart is used, use caution when moving the cart / apparatus combination to avoid injury from tip-over
Quick stops, excessive force, and uneven surfaces may cause the appliance and cart combination to overturn
- 13) Unplug this apparatus during lightning storms or when unused for long periods of time
This will prevent damage to the product due to Lightning and power-line surges
- 14) Refer all servicing to qualified service personnel Servicing is required when the apparatus has been damaged in any way, such as power-supply cord or plug is damaged, liquid has been spilled or objects have fallen into the apparatus, the apparatus has been exposed to rain or moisture, does not operate normally or has been dropped



CAUTION · This TV set for use only with TV-stand (Model TY-S30WX50) Use with other stand is capable of resulting in stability causing possible injury

Dear Panasonic Customer

Welcome to the Panasonic family of customers We hope that you will have many years of enjoyment from your new color television set

To obtain maximum benefit from your set, please read these Instructions before making any adjustments, and retain them for future reference

Retain your purchase receipt also, and note down the model number and serial number of your set in the space provided on the back cover of these instructions

Visit our Panasonic Web Site for USA

www.panasonic.com

For assistance, please call : 1-888-VIEW-PTV(843-9788)

or send e-mail to consumerproducts@panasonic.com

or visit us at www.panasonic.com

(U.S.A)

For assistance, please call : 787-750-4300

(Puerto Rico)

FCC CAUTION

Pursuant to 47CFR, Part 15.21 of the FCC rules, any changes or modifications to this TV not expressly approved by Matsushita Electric Corporation of America could result in harmful interference and would void the user's authority to operate this device

Table of Contents

Important Safety Instructions	2	Playing games in game mode	28
Installation	6	Recall / Mute	29
Receiver Location	6	Split screen	30
Optional External Equipment	6	Adjusting screen position and size	32
AC Power Supply Cord	6	Audio Adjustments	34
Safety Precaution	6	Picture Adjustments	36
Remote Control Battery Installation	7	Playing special video software	39
Connecting the Antenna Cable to the RF In Terminal	8	Closed Captions	40
Antenna / Cable Connection	9	Lock Feature	42
How to connect the "1, 2, 3, 4" input terminals	11	Customizing the VIDEO INPUT labels	46
How to connect the COMPONENT VIDEO Input Terminals	12	Selecting STEREO/SAP/MONO	48
How to connect the AV Prog. Out Terminals	12	Using the off-timer	49
Connecting Headphones / Earphones	13	Viewing with reduced brightness (POWER SAVE)	50
Location of Controls	14	Video game player to VIDEO INPUT	51
Illuminated Remote Control	14	Optimizing display for DVC recording mode (DVC PLAYBACK MODE)	52
Controls and Terminals on the TV	16	Adjusting unnatural video images (3D Y/C FILTER)	53
Power ON / OFF	17	Automatically changing screen size for VIDEO INPUT modes	54
Connecting the Plug to the Wall Outlet	17	Cancelling automatic enlarging of screen	55
How to Turn the Power On	17	Setting when 480p signals (sequential scan) are	
Flow Chart of Main Menu	18	input through COMPONENT VIDEO INPUT	56
Tuning channels (Automatic channel programming)	20	Geomagnetic correction (Adjusting skewing of images)	57
Tuning channels (Manual channel programming)	21	Switching languages for display	58
ASPECT Controls	22	Operating peripheral equipment using the remote control	59
VHF, UHF and CATV	24	Troubleshooting	67
Cable TV	25	Specifications	71
Searching for the desired channel (channel search)	26		
Playing a VCR or other peripheral equipment			
(changing input modes)	27		

Installation

Receiver Location

This unit is intended to be used with an optional stand or entertainment center. Consult your dealer for available options. Locate for comfortable viewing. Avoid placing where sunlight or other bright light (including reflections) will fall on the screen.

Use of some types of fluorescent lighting can reduce remote control transmitter range.

Adequate ventilation is essential to prevent internal component failure. Keep away from areas of excessive heat or moisture. To insure optimum color purity do not position magnetic equipment (motors, fans, other speakers, etc.) nearby.

Optional External Equipment

The Video/Audio connection between components can be made with shielded video and audio cables. For best performance, video cables should utilize 75 ohm coaxial shielded wire. Cables are available from your dealer or electronic supply store. Before you purchase any cables, be sure you know what type of output and input connectors your various components require. Also determine the length of cable you'll need.

AC Power Supply Cord

CAUTION: To prevent electric shock, match wide blade of plug to wide slot of AC outlet and fully insert. Do not use this (polarized) plug with a receptacle or other outlet unless the blade can be fully inserted to prevent blade exposure.

Safety Precaution

Please take safety precautions to prevent the unit from falling over.

The unit may fall over during earthquakes, or if someone stands on, or shakes, the TV.

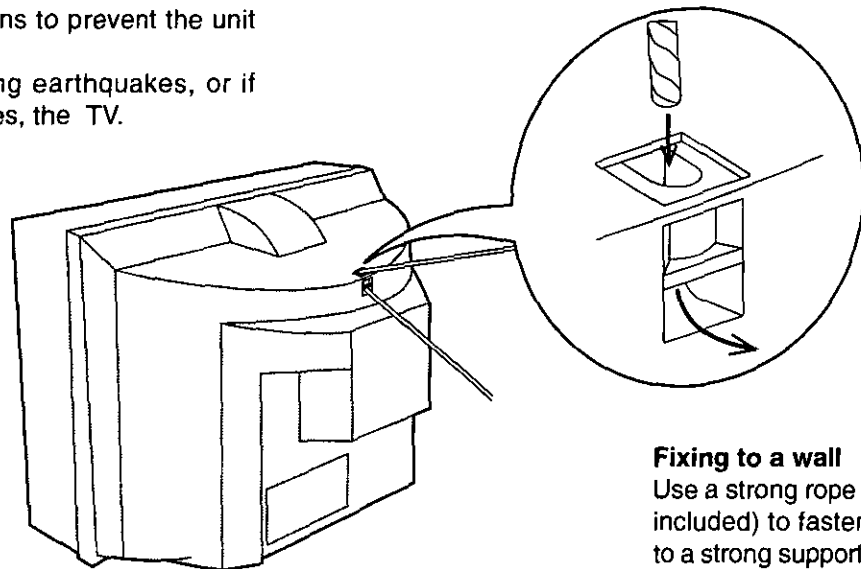

Fixing to a wall

Use a strong rope or a chain (not included) to fasten the TV firmly to a strong support such as a wall or pillar.

Remote Control Battery Installation

Requires two AA batteries

- 1 Turn the Transmitter face down. Remove top cover by pressing down on marking and sliding cover off in the direction indicated.
- 2 Install the batteries as shown in the battery compartment (Polarity + or – must match the markings in the compartment).
- 3 Replace the cover and slide in reverse until the lock snaps.

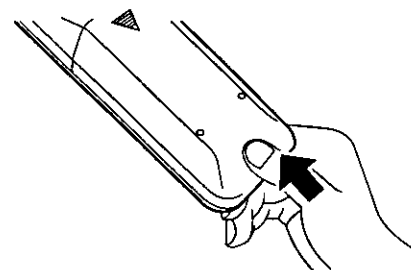
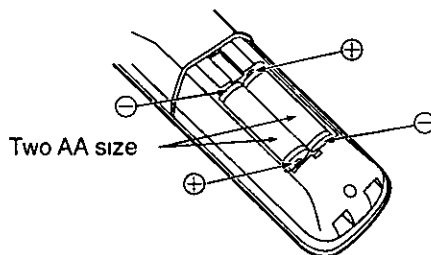
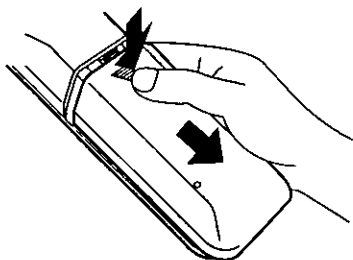

Helpful Hint:

For frequent remote control users, replace old batteries with Alkaline batteries for longer life.

Note: In order to maximize the life of the batteries, the lighted buttons on the Remote Control can be turned OFF and ON by pressing R-TUNE and RECALL at the same time.

⚠ Precaution on battery use

Incorrect installation can cause battery leakage and corrosion that will damage the remote control transmitter.

Observe the following precautions:

- 1 Batteries should always be replaced as a pair. Always use new batteries when replacing the old set.
- 2 Do not combine a used battery with a new one.
- 3 Do not mix battery types (example "Zinc Carbon" with "Alkaline").
- 4 Do not attempt to charge, short-circuit, disassemble, heat or burn used batteries.
- 5 Battery replacement is necessary when remote control acts sporadically or stops operating the TV set.

Helpful Hint:

Whenever you remove the batteries, **you may need to reset the remote control infrared codes**. We recommend that you record the code on page 62, prior to setting up the remote.

Installation

Connecting the Antenna Cable to the RF In Terminal

Antenna Connection - For proper reception of VHF/UHF channels, an external antenna is required. For best reception an outdoor antenna is recommended. Antenna Mode must be set to TV.

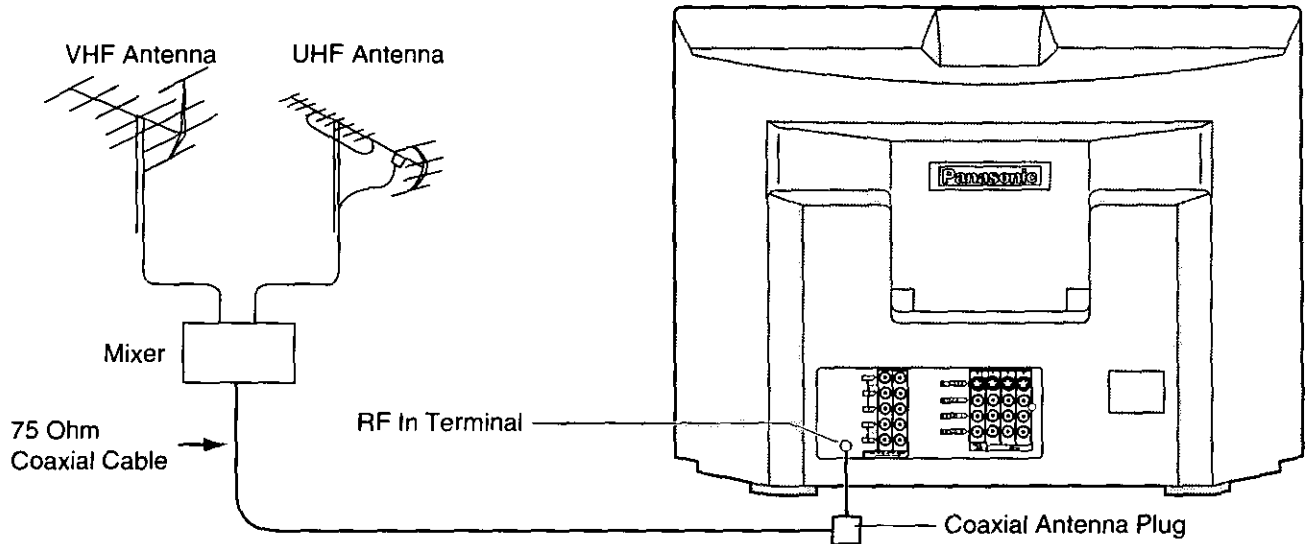

Antenna / Cable Connection

Incoming Cable From Home Antenna (75 Ohm)

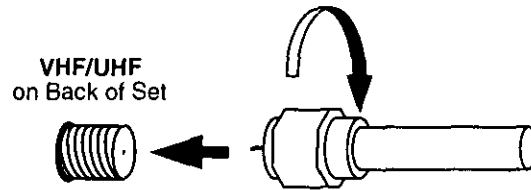

Incoming 75 Ohm Cable (From Cable Company)

Cable Connection - For reception of cable channels (01 - 125) connect the cable supplied by your local cable company. Antenna Mode must be set to CABLE (Refer to Antenna Mode section)

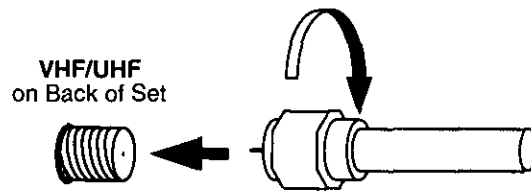

Note:

Certain cable systems offset some channels to reduce interference or have Premium (scrambled) channels. A cable converter box is required for proper reception. Check with your local Cable company for its compatibility requirements.

Installation

Antenna Connection (Cable Box, no VCR)

Use this configuration when connecting the TV to a cable TV system using a Cable Box.

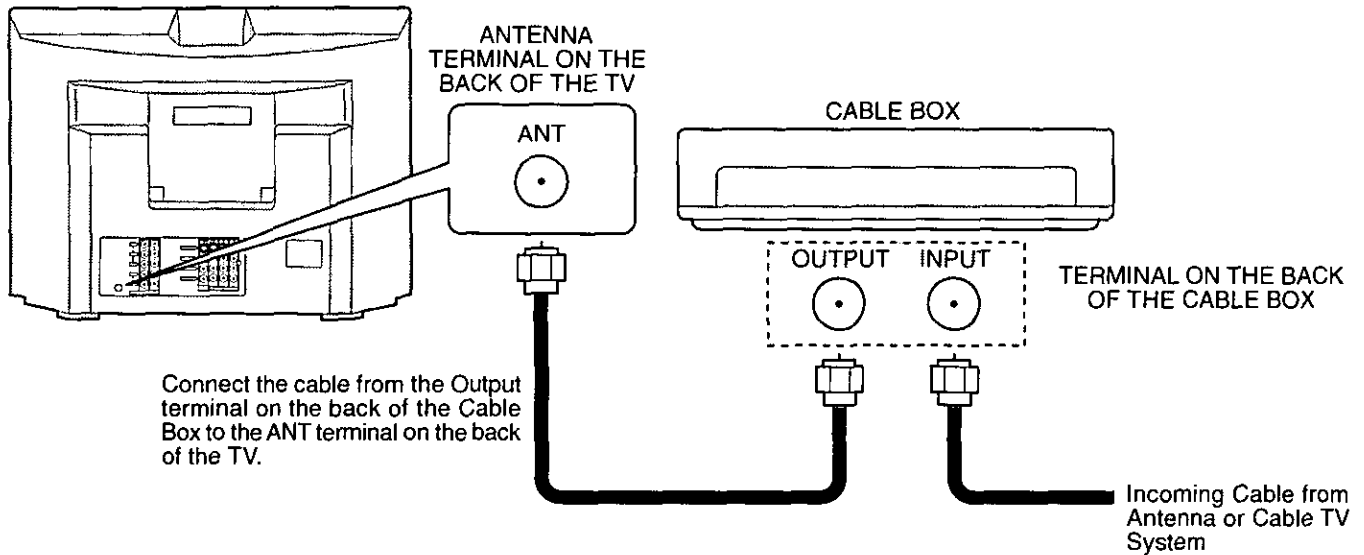

Antenna Connection (Cable Box, and VCR)

Use this configuration when connecting the TV to a cable TV system using a Cable Box and VCR.

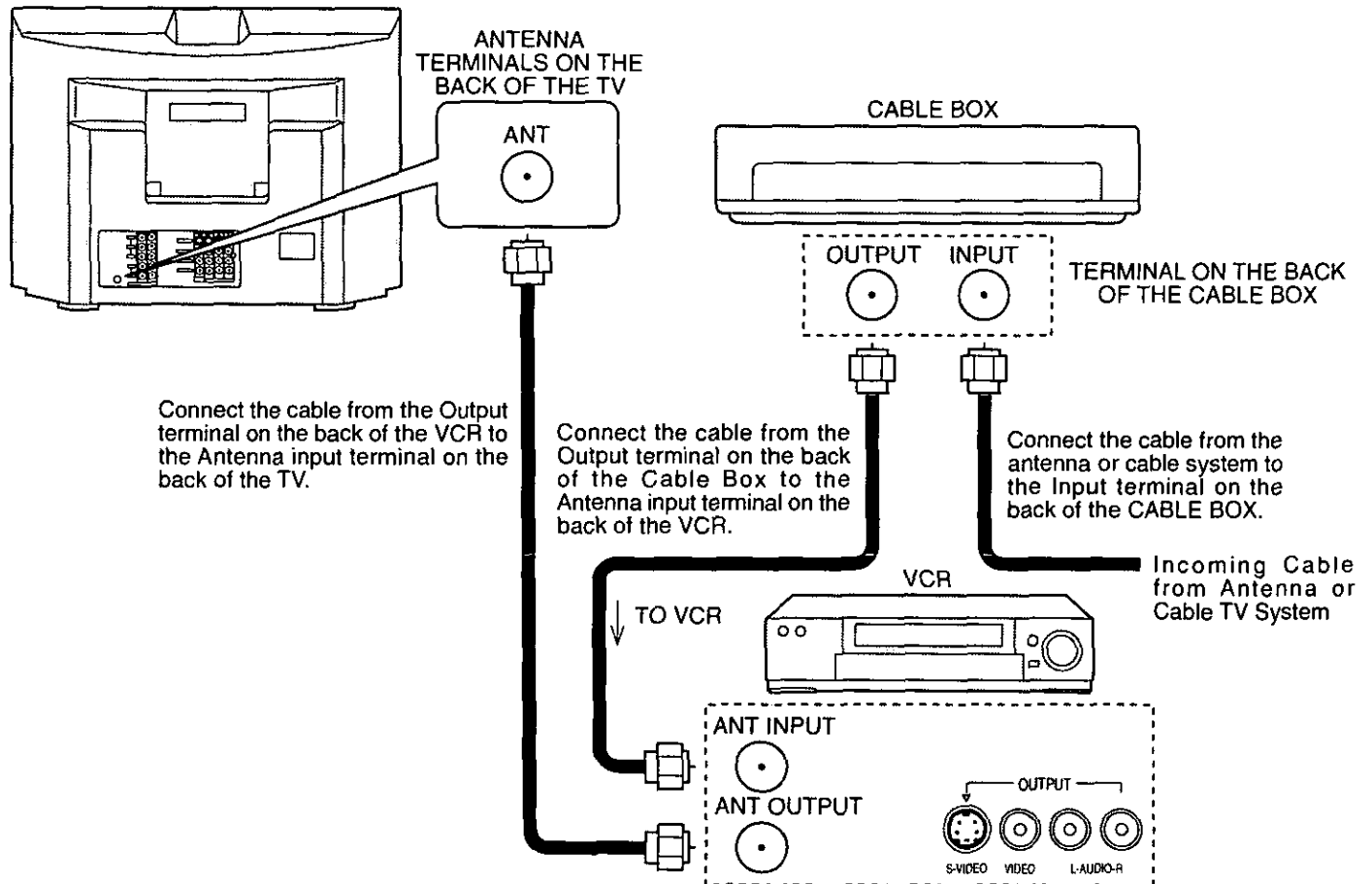

Note: When the antenna cable is connected to the TV antenna terminal via a cable box or VCR, set the TV channel to CH3 or CH4, cable. This does not apply when signal is input from VIDEO INPUT.

How to connect the "1, 2, 3, 4" input terminals

Connects VCRs and other peripheral equipment

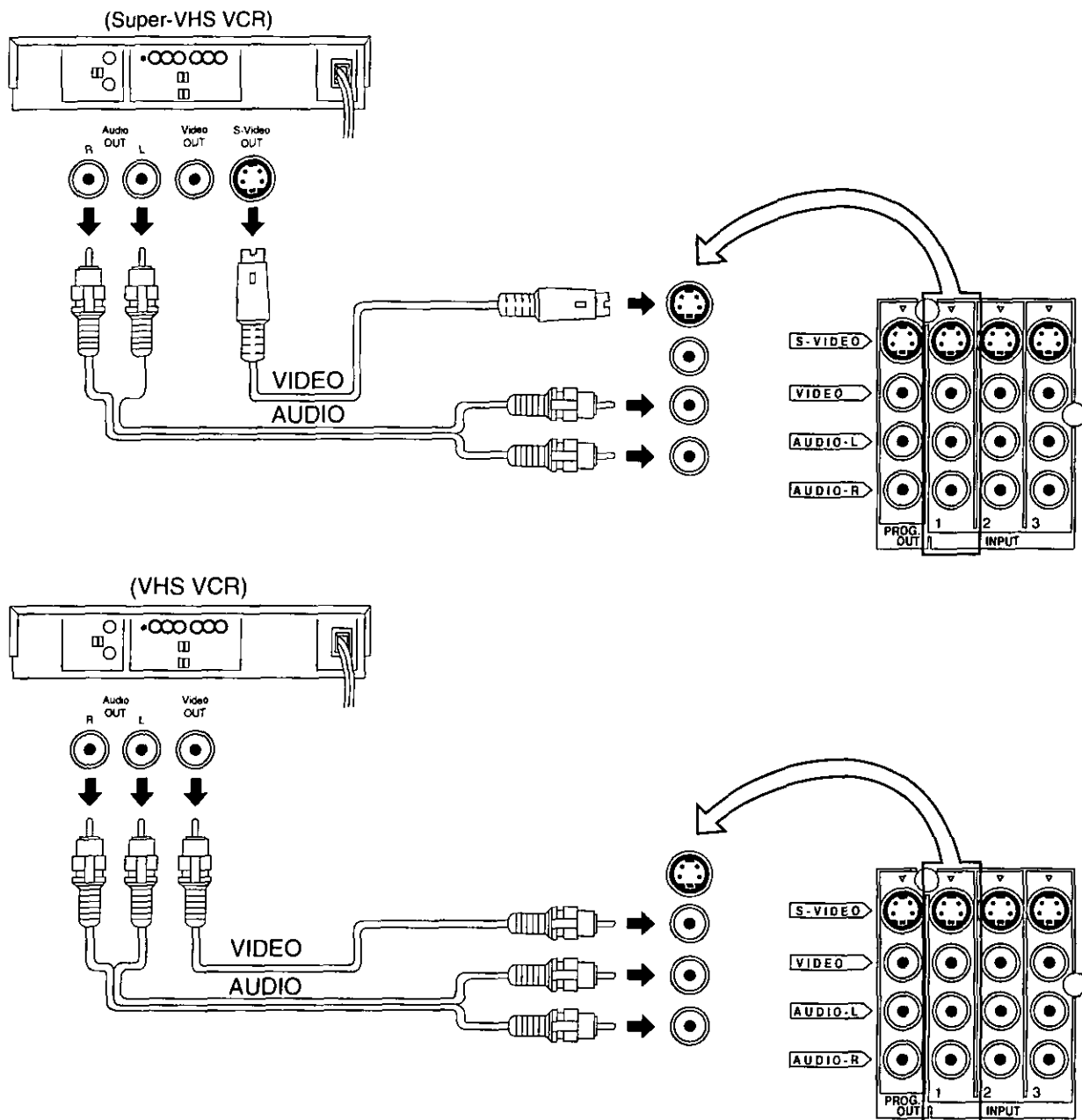

Notes:

- (1) When a monaural VCR is used, connect the monaural audio cable to the AUDIO-L (Left) terminal.
- (2) Similar connections are available at the INPUT 1, 2, 3, 4 input terminals. Input 4 is located on the front of the unit. Select the desired VIDEO input position by pushing the TV/VIDEO button. (See page 27)
- (3) When connecting video cables, priority is given to the S-Video cable when the S-Video input terminal and the video input terminal are connected at the same time.

Installation

How to connect the COMPONENT VIDEO Input Terminals

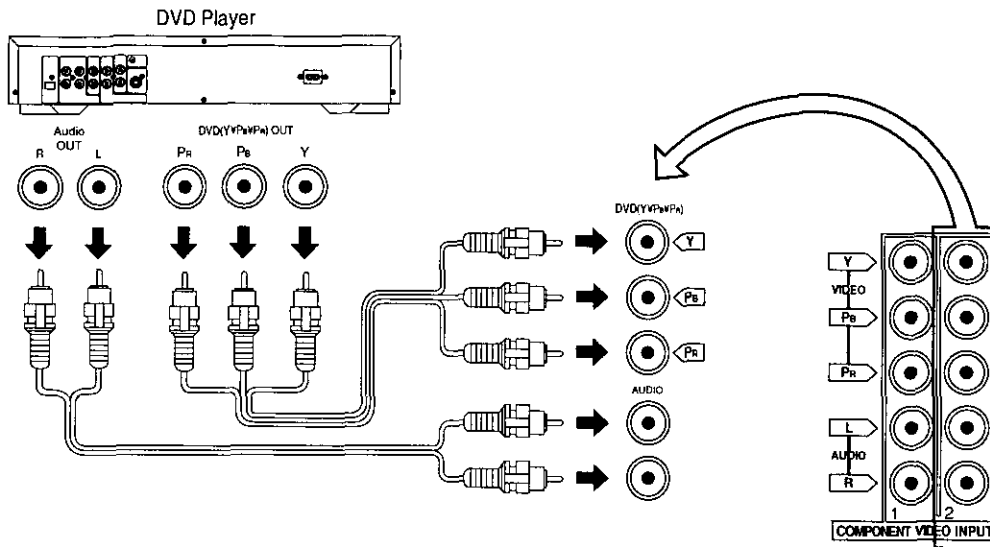

How to connect the AV Prog. Out Terminals

The "Prog. Out" Terminals output the same signals as main picture on the TV screen and sound from the speaker at that time, e.g. TV programs or signals from INPUT 1, 2, 3, 4 terminals.

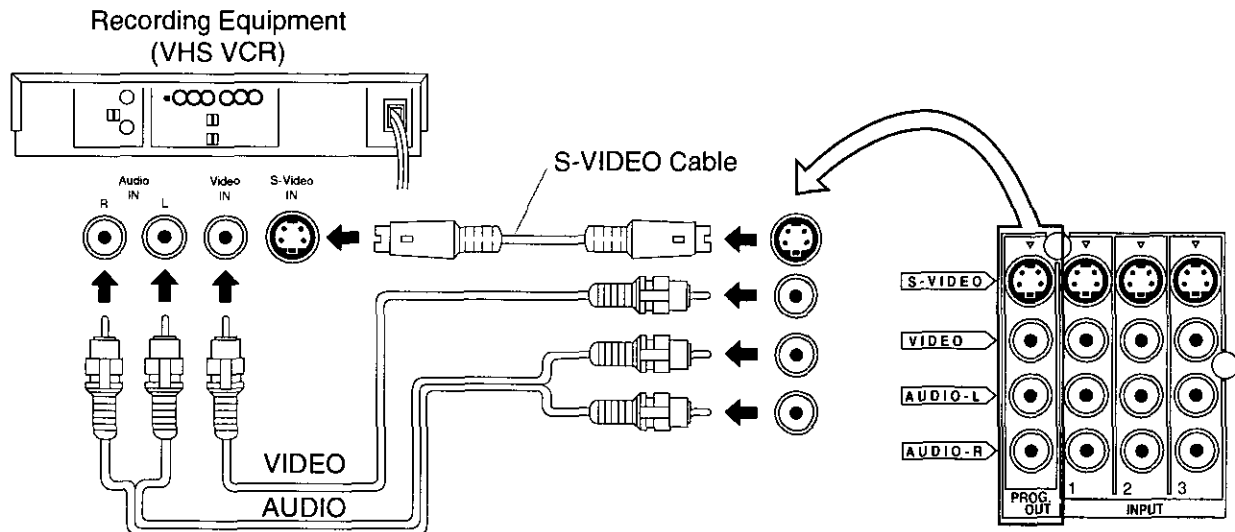

Notes:

- (1) Never connect the VIDEO IN and Prog. OUT terminals to the same video recorder, as this could cause incorrect operation.
- (2) The monitor output emits the main picture normal video and audio signals.
- (3) Even if the television is in picture-out-picture condition, Prog. OUT terminals output the same signals as main picture on the screen and sound from speaker. Sub picture including strobe, still, channel search, etc. will not be output at the PROG. OUT terminals.
- (4) DVD signal (Y, Pb, Pr) is not output at the Prog. OUT terminals.
- (5) COMPONENT VIDEO INPUT

In order to prevent colors from interfering, image signals are divided into three signals of brightness, red and blue (green is created automatically from these three signals). Each signal is processed from its own circuit and combined on the screen, creating a natural picture.

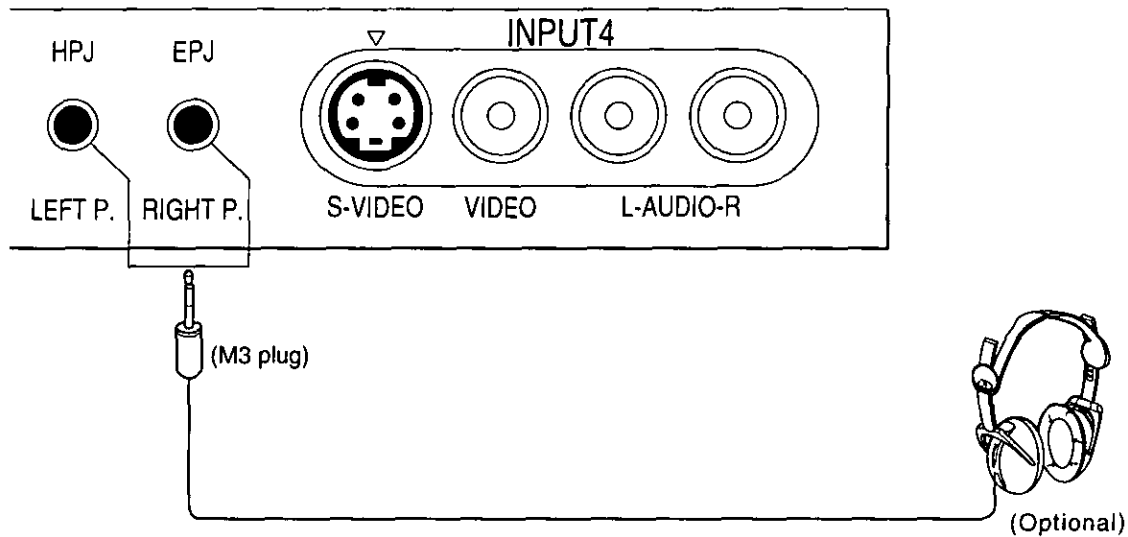

Connecting Headphones / Earphones

Connect headphones / earphones as follows.

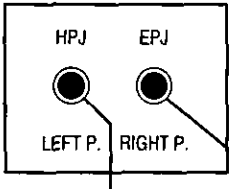
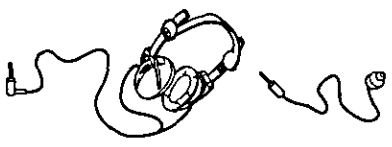
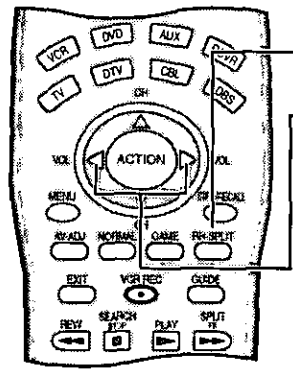

You can listen to sound from each of the headphones Jacks as shown below.

Front jack

 <p>HPJ EPJ LEFT P. RIGHT P.</p> <p>Sounds from speakers are turned off.</p> <p>Speakers also function.</p>	<p>M3 plug jack Headphones (stereo) or earphones (monaural)</p>  <ul style="list-style-type: none"> ● Volume and sound effects will vary, depending on the connected headphones or earphones. 	<p>RIGHT P. (PICTURE)</p> <ul style="list-style-type: none"> ● During single screen, volume adjustments can be made. ● During split screen, sound from the right screen is played and its volume adjustments can be made.  <ol style="list-style-type: none"> 1. Press the RH-SPLIT button. 2. Immediately make volume adjustments. 
--	--	--

LEFT headphones plug:

When a LEFT headphones plug is inserted into the LEFT headphones socket, all speakers will be automatically disconnected; only the headphones will function.

Use Volume Up ► or Down ◀ button to control volume level.

Location of Controls

Illuminated Remote Control

Power button

Press to turn the TV ON or OFF (See page 17)

Note.

The TV's power cord must first be plugged into the wall outlet and then turned on at the POWER switch (standby mode)

MUTE button

Push this button to mute the sound (See page 29)

Mode Selection buttons

Selects the operation mode for the remote control (See page 58)

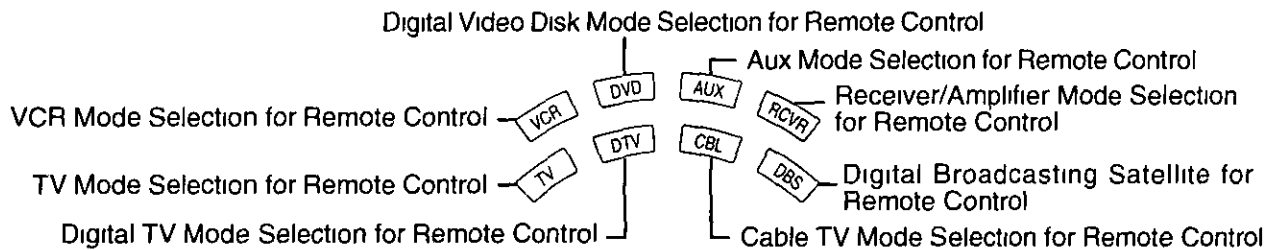

Operation of other Device

Buttons				
TV	—	Split search	—	Split ON/OFF
VCR	REW	STOP	PLAY	FF
CABLE/DBS	—	—	—	—
DVD/LD/CD	Skip Search REW	STOP	PLAY	Skip Search FF
RCVR	Srround -	—	—	Surround +

Buttons				
TV	Split Freeze	—	—	Split Swap
VCR	TV/VCR switch	Channel down	Channel down	Pause
CABLE/DBS	—	Channel down	Channel down	—
DVD/LD/CD	Open/Close	Slow-/LD-side B /Random	Slow-/LD-side A /Repeat	Still/Pause
RCVR	—	Center -	Center +	—

R-TUNE



R-TUNE button

Switches to previously view to channel or video mode

Location of Controls

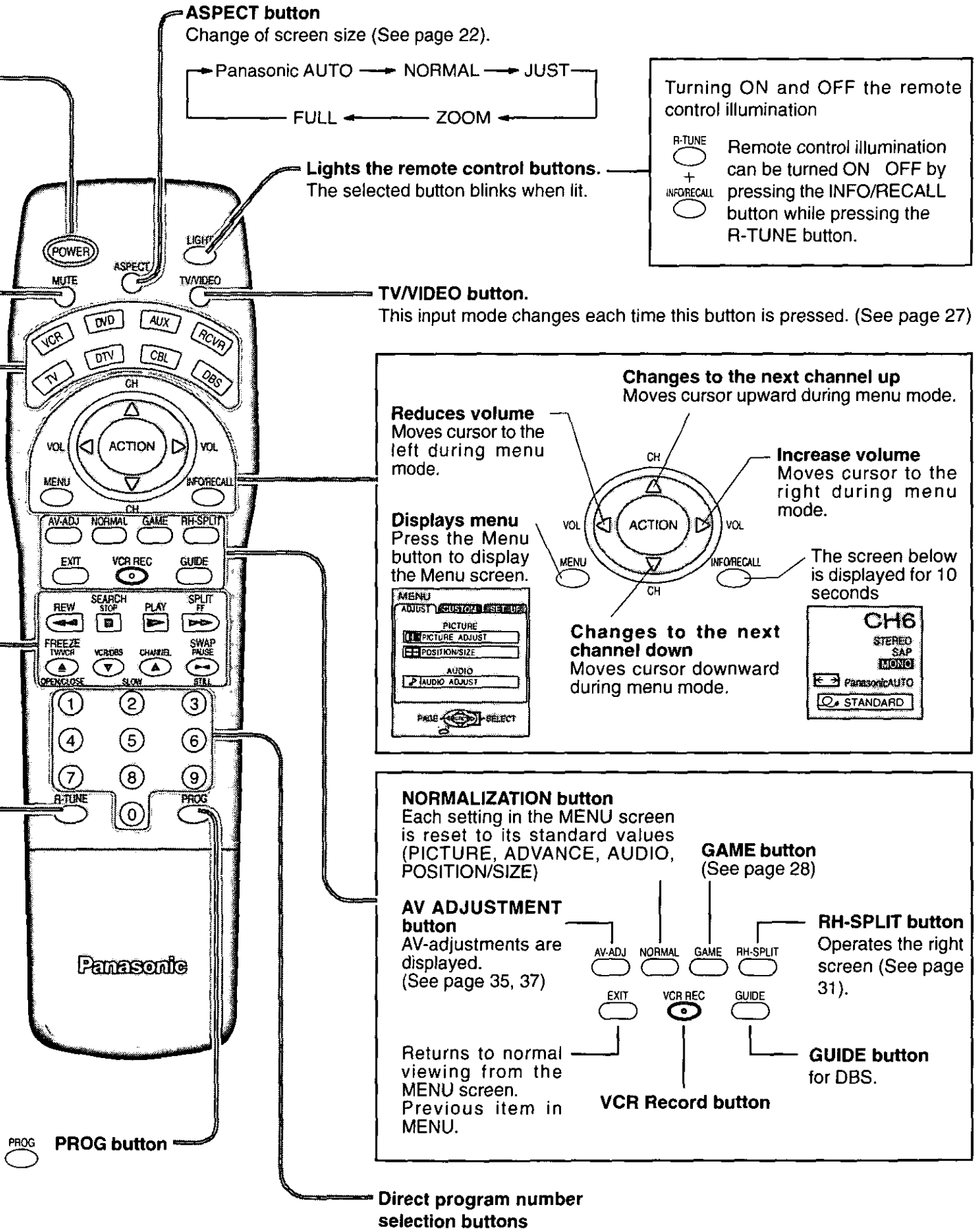

Location of Controls

Controls and Terminals on the TV

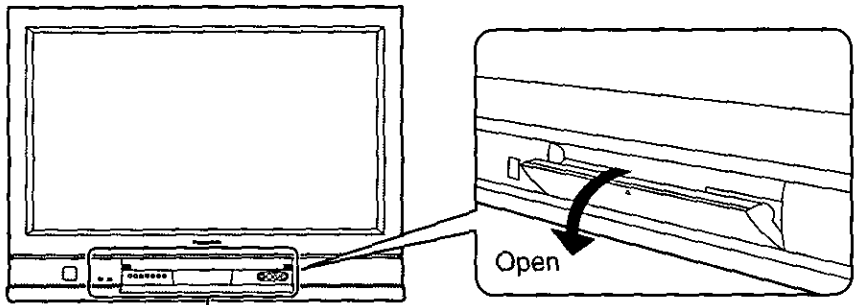

Press the ▲ mark on the center of the front cover to open

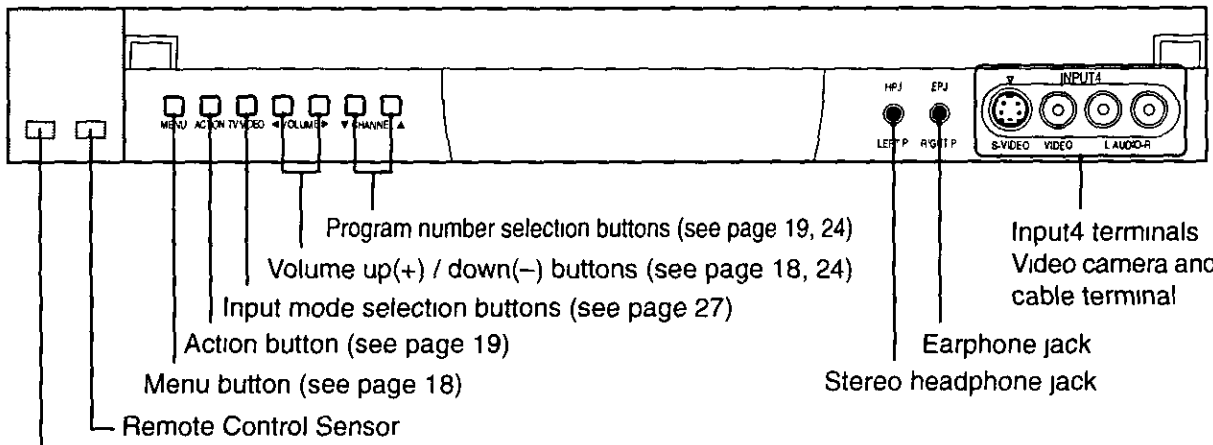

Remote Control Sensor
 Menu button (see page 18)
 Action button (see page 19)
 Input mode selection buttons (see page 27)
 Volume up(+) / down(-) buttons (see page 18, 24)
 Program number selection buttons (see page 19, 24)

Earphone jack
 Stereo headphone jack
 Input4 terminals
 Video camera and TV game cable terminal

Power Indicator

The Power Indicator will light

- Power-OFF Indicator not illuminated (The unit will still consume some power as long as the power cord is still inserted into the wall outlet)
- Stand-by ○ Red
- Power-ON Green

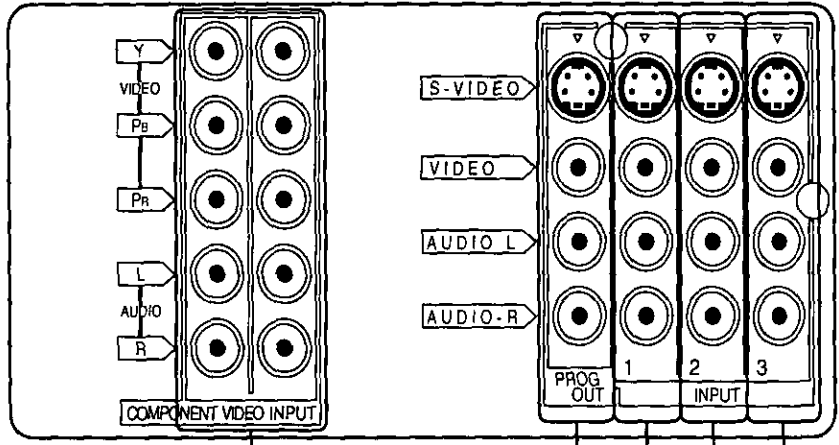
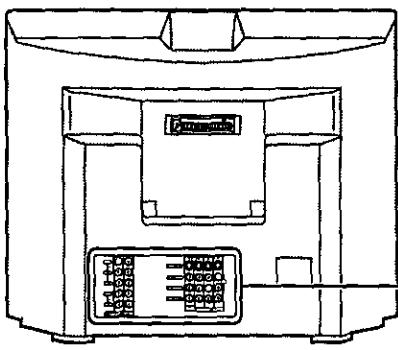

Component signal input
 Monitor out terminals
 Input1 terminals
 Input2 terminals
 Input3 terminals

Power ON / OFF

Connecting the Plug to the Wall Outlet

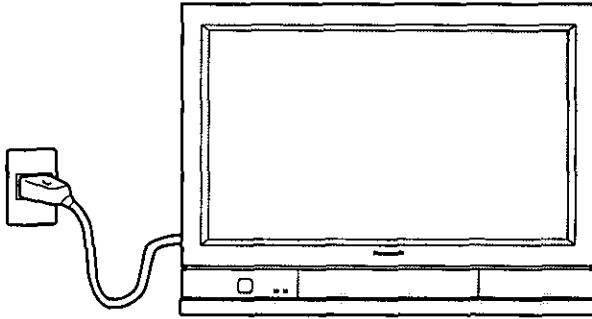

Note:

Main plug types vary between countries. The power plug shown at left may, therefore, not be the type fitted to your set.

How to Turn the Power On

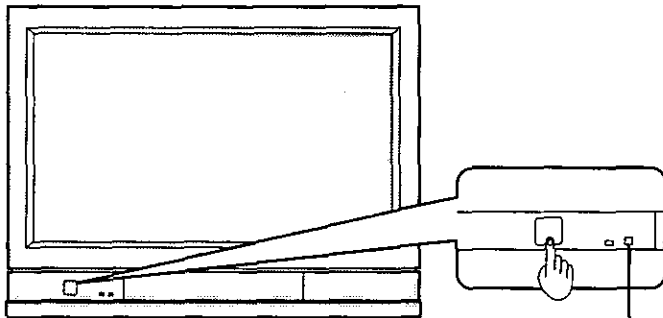

Remote Control Sensor

Push the POWER switch on the TV to turn the set on.
POWER-ON: Green

Example: The screen below is displayed for a while after the TV is turned on. (setting condition is an example.)

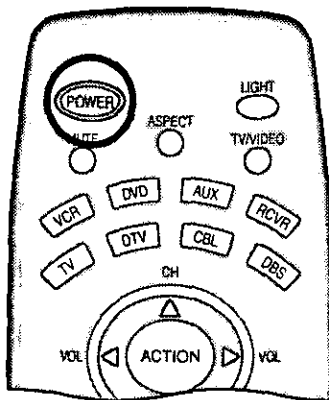
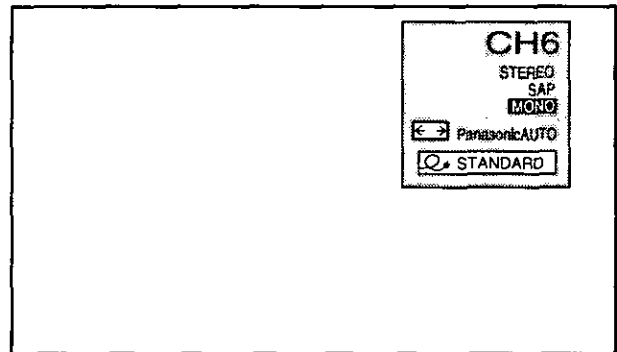

Press the POWER button on the remote control to turn the TV off: Red (standby)

Press the POWER button on the remote control to turn the TV on: Green

Turn the power to the TV set off by pressing the POWER switch on the TV when the TV is on or in standby mode.

Flow Chart of Main menu

1

If the MENU button is pressed, the MENU screen will be displayed
 If the MENU button is pressed once more while the menu screen is displayed, the MENU screen will be cleared

The MENU button on the main body can also be pressed to display the MENU screen

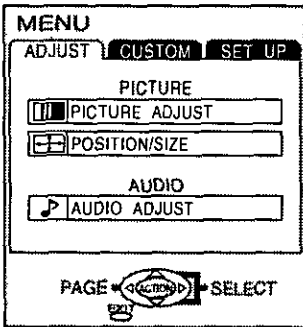

2

Select MENU desired by pushing Right "▶" button or Left "◀" button

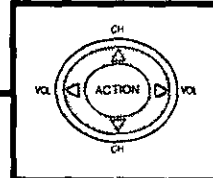

The MENU button on the main body can also be pressed to display the MENU screen

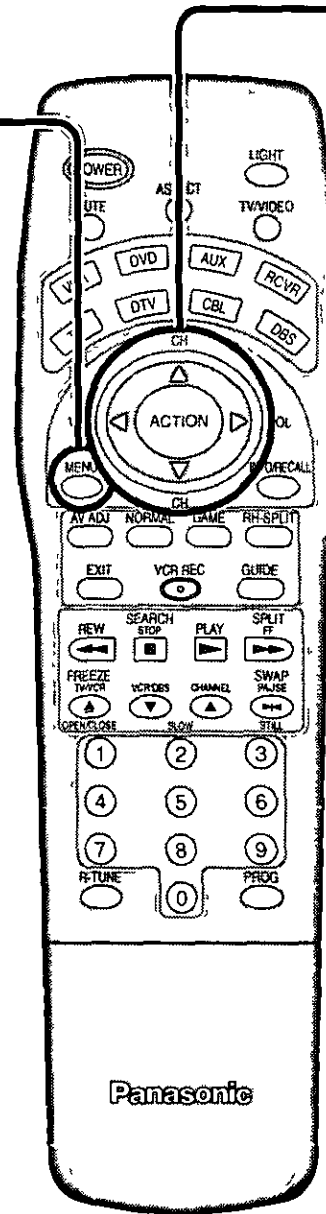
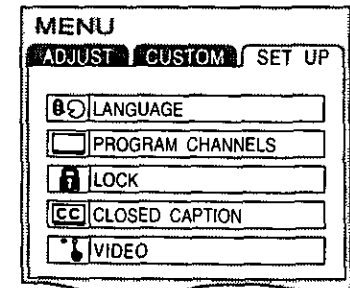
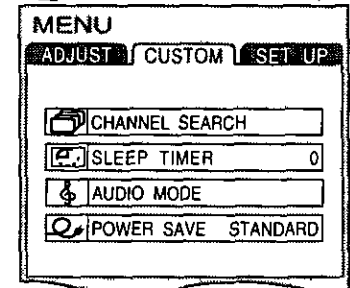
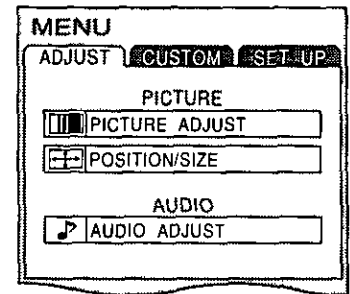
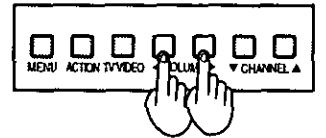

Panasonic

Flow Chart of Main menu

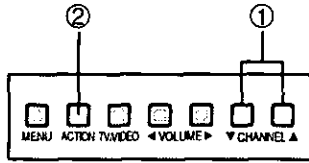
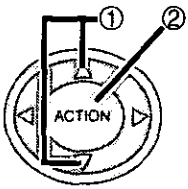

The MENU button on the main body can also be pressed to display the MENU screen.

TO PICTURE ADJUST menu

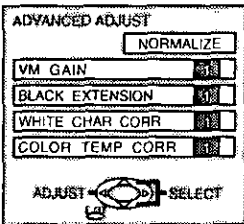
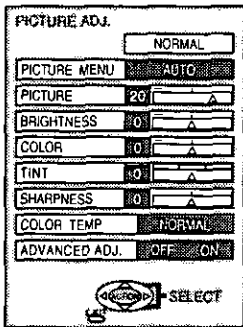

TO POSITION/ SIZE

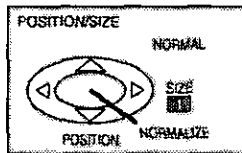

TO AUDIO ADJUST menu

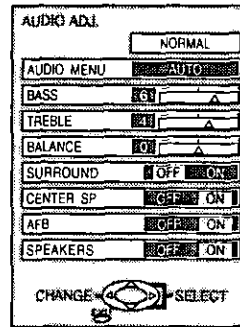

TO CHANNEL SEARCH screen

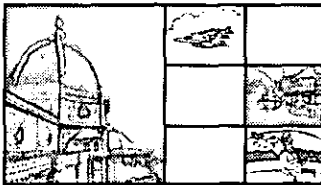

TO SLEEP TIMER adjust screen

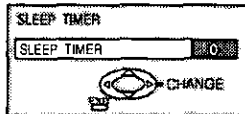

TO AUDIO MODE adjust screen

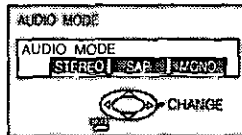

TO POWER SAVE adjust screen

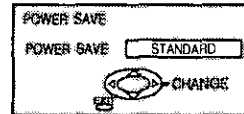

TO LANGUAGE selection screen

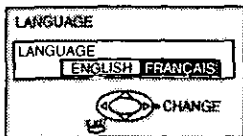

TO PROGRAM CHANNELS adjust screen

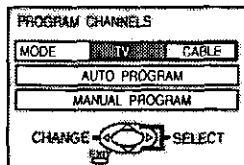

TO LOCK selection screen

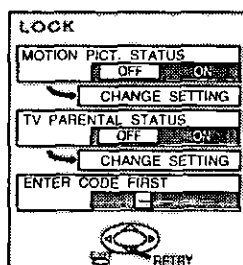

TO CLOSED CAPTION selection screen

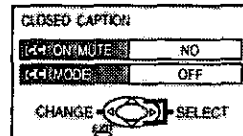

TO VIDEO adjust screen

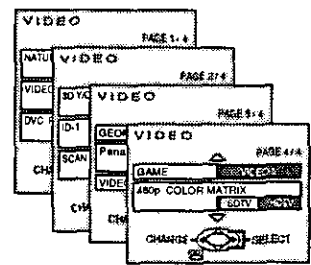

Tuning channels (Automatic channel programming)

Automatically searches and adds receivable channels in the installed area and/or CATV signals to the program.

Channel tuning cannot be performed when the MAIN picture is not receiving a TV broadcast (tuning is not possible)

1 Press the MENU button to display the MENU screen and select SETUP

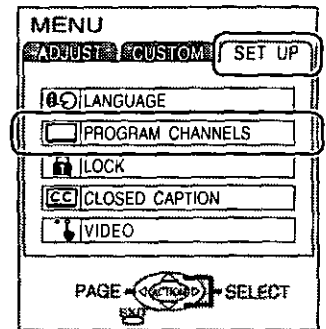
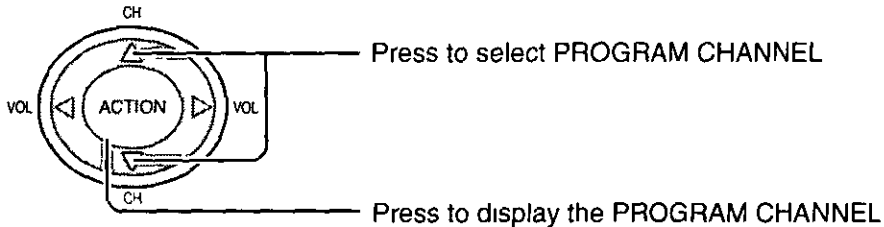

2 Press to select MODE

Press to select TV or CABLE

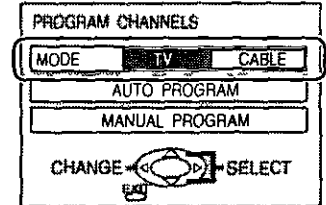
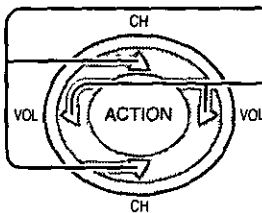

3 Press to select AUTO PROGRAM

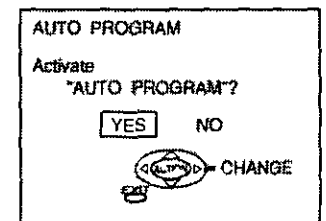
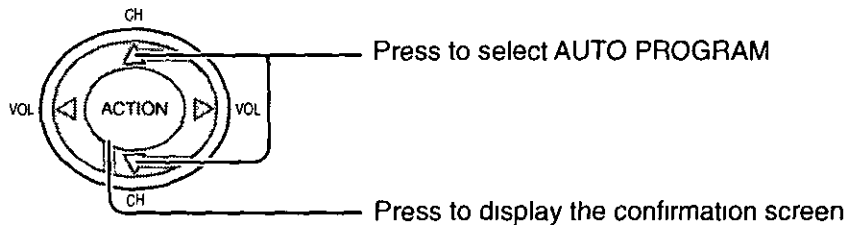

4 Press to select YES

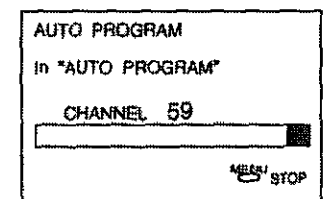
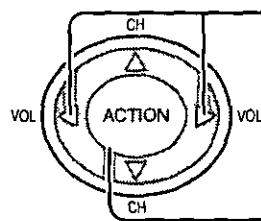

Channels will automatically advance until all channels have been scanned. Channel numbers with a video signal present will turn blue, which indicates it has been stored in the Channel Scan Memory.

5 Press the MENU button to exit the set up menu

Notes:

- When buttons are pressed with AUTO PROGRAM running, the TV set will return to normal viewing (Channel searched up to this point are added)
- After AUTO PROGRAM is finished, the lowest channel number added will be received
- When there are no receivable channels, channel 69 is displayed (channel 125 for cable TV)

Tuning channels (Manual channel programming)

Use this setting when changing setting of receiving channels or changing the channel display.

Turn the TV on and select the broadcast channel. Follow the steps on the previous page to display the PROGRAM CHANNEL screen.

This PROGRAM CHANNEL screen can be displayed when the MAIN picture is a TV broadcast.

Selecting the PROGRAM CHANNELS menu.

Press the MENU button to display the MENU screen and select SET UP.

1

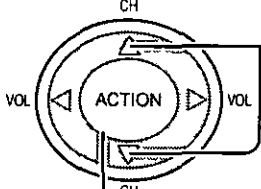

Press to select PROGRAM CHANNELS

Press to display the PROGRAM CHANNEL

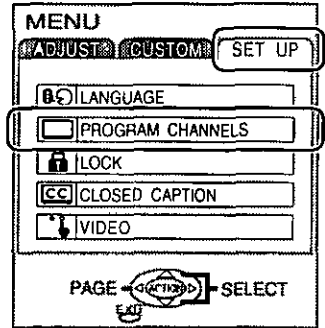

2

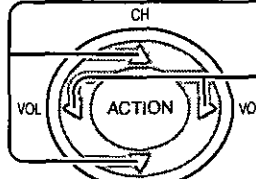

Press to select MODE

Press to select TV or CABLE

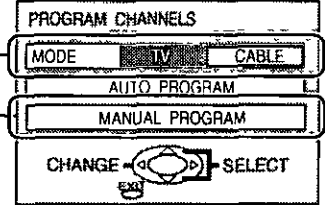

3

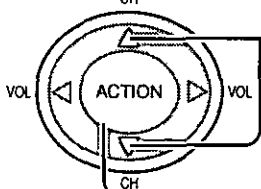

Press to select MANUAL PROGRAM

Press to display the MANUAL PROGRAM screen

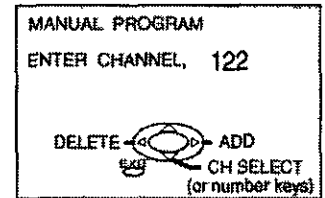

Adding or deleting channels

4

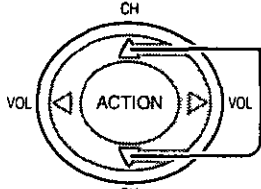

Press to select channel (or number keys)

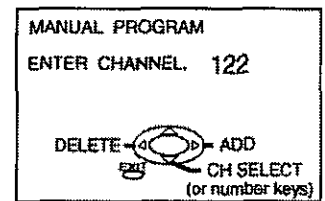

5

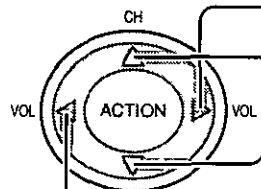

Press to add channels to memory (blue)

Press to select channel

Press to delete channels from memory (yellow)

6 Repeat steps 4 and 5 to continue adding or deleting channels

7 Press the MENU button to exit the set up menu

ASPECT Controls

The color monitor will allow you to enjoy viewing the picture at its maximum size, including wide screen cinema format picture

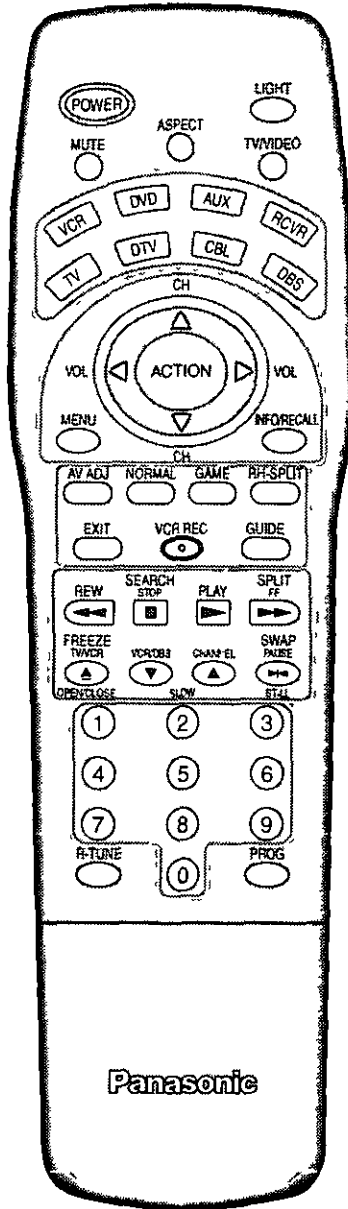

ASPECT button

The aspect mode changes each time the ASPECT button is pressed

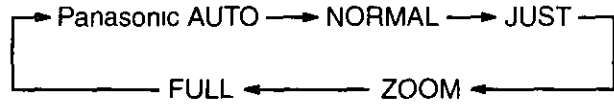

Notes:

- (1) For a 480p signal input during component input signal mode, the mode switches between ZOOM and FULL only
- (2) When a 1080i signal is being received, the mode is set to FULL, and aspect switching is not possible
- (3) During split screen, modes will change as follows

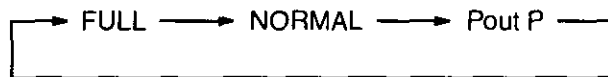

ASPECT Controls

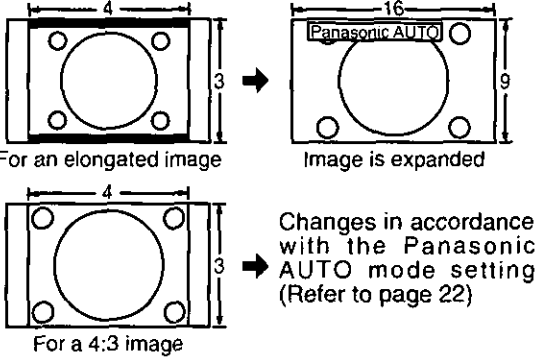
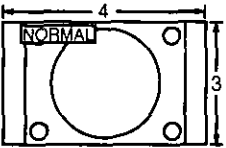
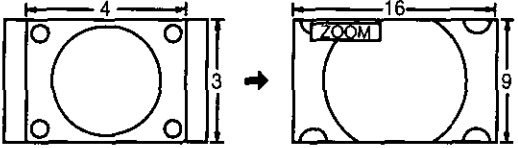
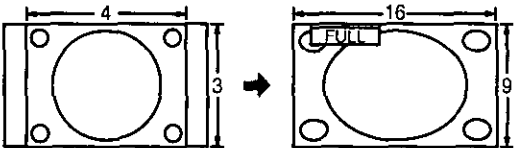
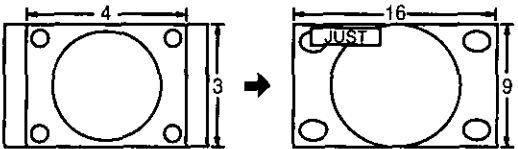
Mode	Picture	Explanation
Panasonic AUTO	 <p>For an elongated image → Image is expanded</p> <p>Changes in accordance with the Panasonic AUTO mode setting (Refer to page 22)</p> <p>For a 4:3 image</p>	<p>The display will automatically become enlarged (depending on the picture source), allowing you to view the picture at its maximum size.</p> <p>Note:</p> <p>(1) If Panasonic Auto mode is selected, the image may change size suddenly, according to program material.</p> <p>(2) There may be a slight delay for the screen size to adjust. If a 480p or 1080i signal is input during component input signal mode, the controls will not operate.</p>
NORMAL		<p>NORMAL will display a 4:3 picture at its standard 4:3 size.</p>
ZOOM		<p>ZOOM mode magnifies the central section of the picture.</p>
FULL		<p>FULL will display the picture at its maximum size but with slight elongation.</p>
JUST		<p>JUST mode will display a 4:3 picture at maximum size but with aspect correction applied to the center of the screen so that elongation is only apparent at the left and right edges of the screen. The size of the picture will depend on the original signal.</p>

Notes:

- (1) The S-VIDEO terminal on this set can detect specially encoded signals that are compatible with a wide screen monitor. When a full image from the S-VIDEO terminal of specially encoded video is detected by the set, the screen size is automatically set to FULL mode.
- (2) The screen size also changes if ID-1 is detected.
- (3) The screen size will also change if S1 detection has been set.

VHF, UHF and CATV

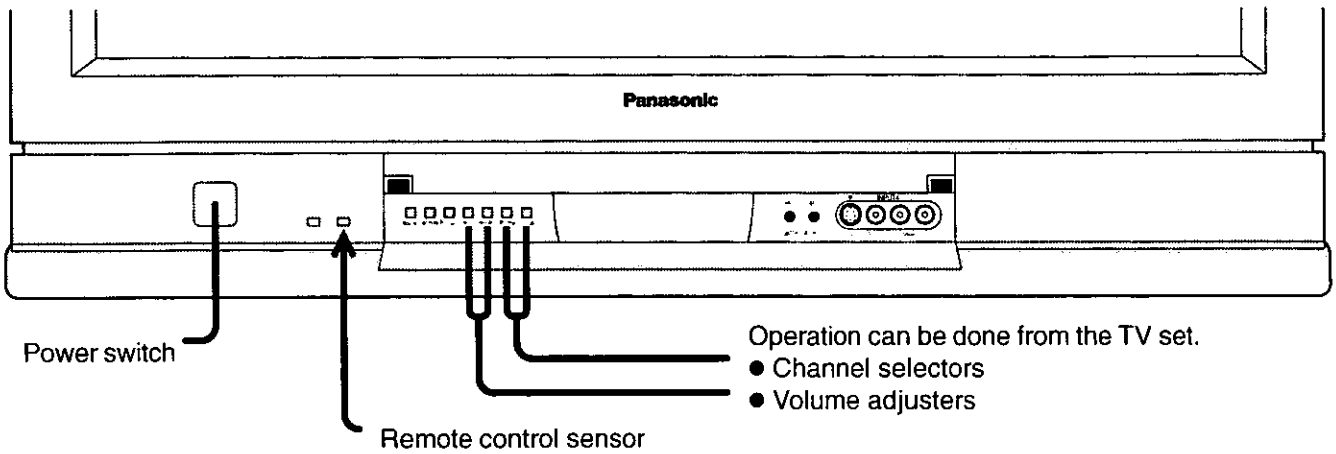

1  Press to turn the TV on (See page 17).

2  Press to operate the TV set with the remote control.

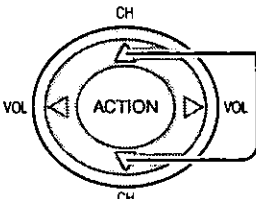
3  Press to select the desired channel.

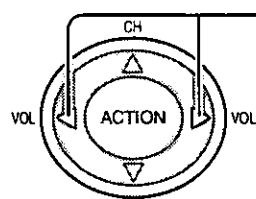
4  Select the desired volume level.

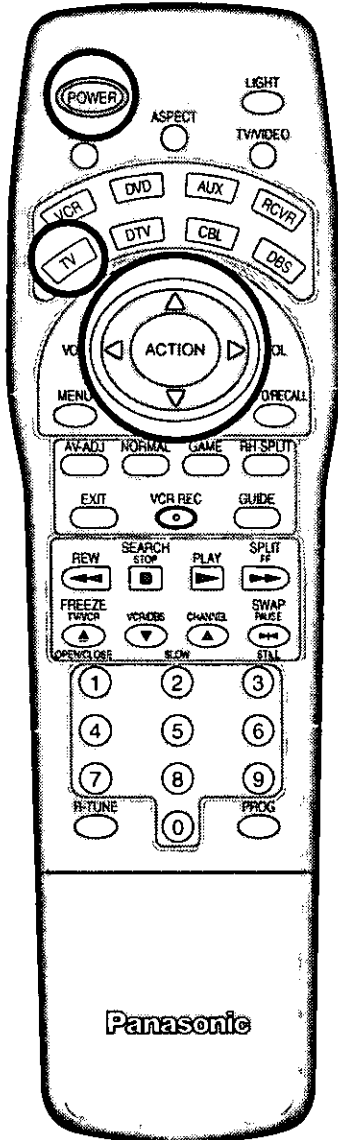

Notes:

- The channel number and volume level are set even after the TV is turned off.
- Power consumption and howling of sound can be reduced if the volume level is lowered.

Cable TV

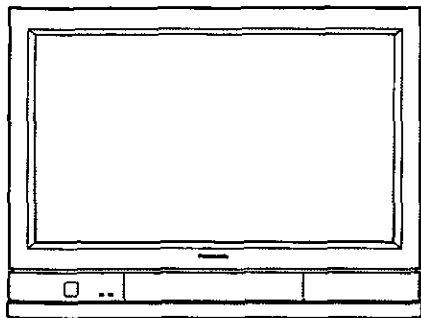

ANTENNA TERMINAL ON THE BACK OF THE TV

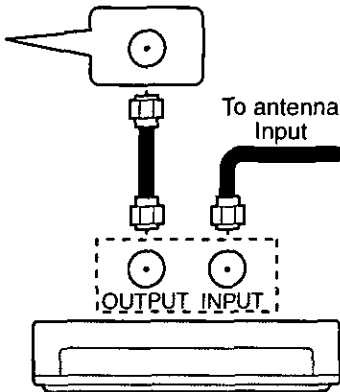

Incoming Cable from Antenna or Cable TV System

CABLE BOX

When the antenna cable is connected to the TV antenna terminal via a cable box or VCR, set the TV channel to CH3 or CH4. This does not apply when signal is input from VIDEO INPUT.

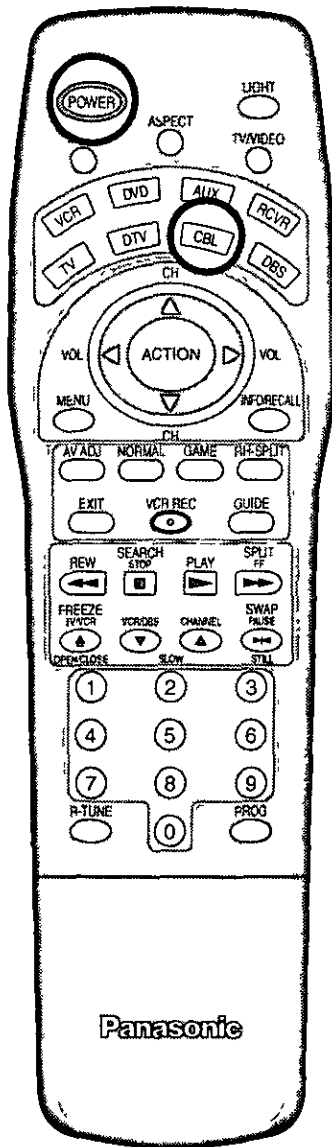

Confirming

Confirm that registration with cable TV and connection of equipment are completed. Turn the cable TV tuner and select the desired volume level.



Press while pointing the remote control towards the cable TV tuner.

Note:
The remote control code number is set for Panasonic products. When peripheral equipment does not operate, reset code (See page 59 and 60).

3 Operate the cable TV tuner and select the desired volume level.

Searching for the desired channel (channel search)



When a SEARCH / STOP button is pressed during single screen

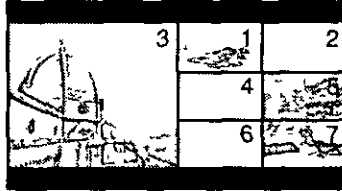
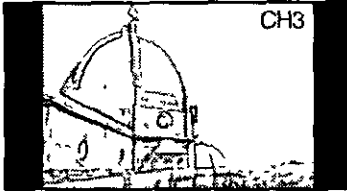

The sound from the left screen will be heard from both [LEFT P] and [RIGHT P] screen jacks (both earphones and headphones)

When a channel button is pressed during channel search

- Number keys
Example When 8 is pressed, channel 8 is displayed in single screen
- Channel up and down keys
When ▲ or ▼ button is pressed, the next channel up or down is displayed in single screen



When a SEARCH / STOP button is pressed during single screen

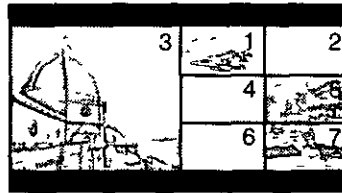

The sound from the left screen will be heard from both [LEFT P] and [RIGHT P] screen jacks (both earphones and headphones)

When a channel button is pressed during channel search.

The selected channel will be displayed on the right screen (pause is deactivated)

Channel search:

Channel search displays each channel, in order, as a paused image. Channels are displayed from the left top to the right bottom in order. When it reaches the right bottom, the next channel is displayed at the left, overwriting the previously displayed channel.

Notes

- To end channel search, press → SEARCH STOP
- Channel search can be activated from the MENU screen

Playing a VCR or other peripheral equipment

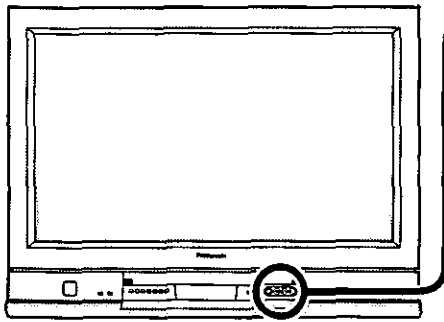

Confirm that the TV is in standby mode.

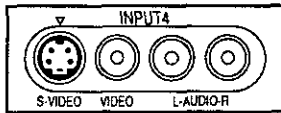

Confirming connections

A video camera uses the Video Input 4 terminal on the front of the TV.

Video camera

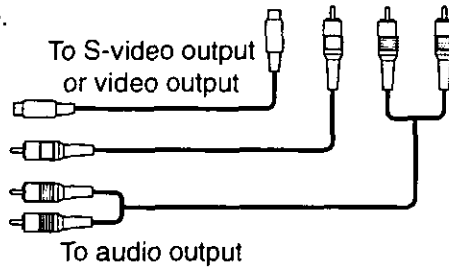
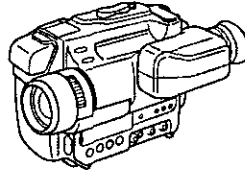

VCR

Laser Disk Player

DVD player

This equipment can also be connected to the rear terminals. See Connections for details.

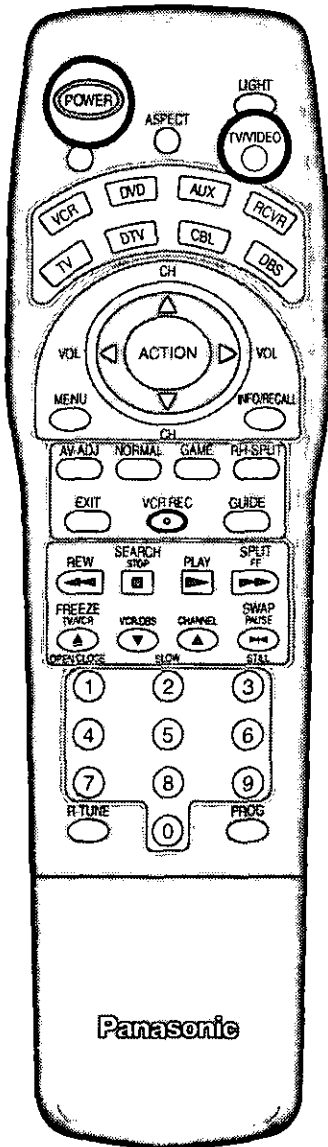

Turning the power on and switching input modes

1 Turn the TV on.

2 The input mode changes each time this button is pressed. (See page 46 and 47)

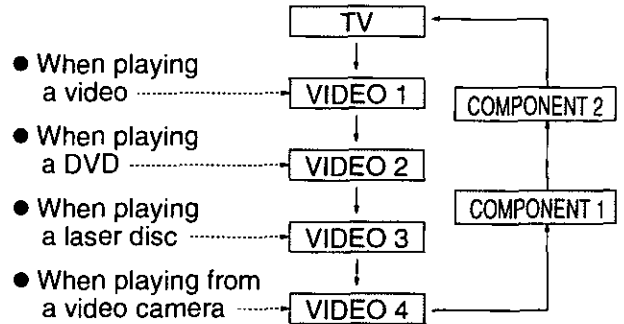

- When playing a video VIDEO 1
 - When playing a DVD VIDEO 2
 - When playing a laser disc VIDEO 3
 - When playing from a video camera VIDEO 4
- (No input mode is displayed for terminals with no equipment connected.)

Note: When the remote control is unavailable, input modes can also be switched on the TV set using the TV/VIDEO button.

3 Operate the connected equipment.

Playing games in game mode

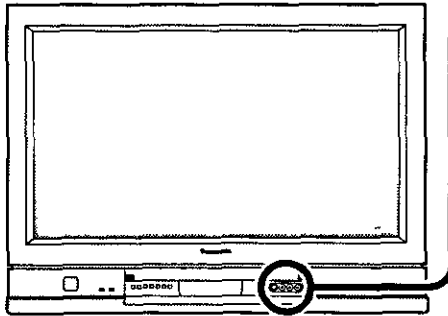

Confirm that the TV is in standby mode

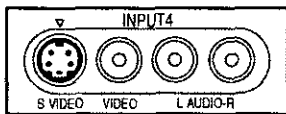

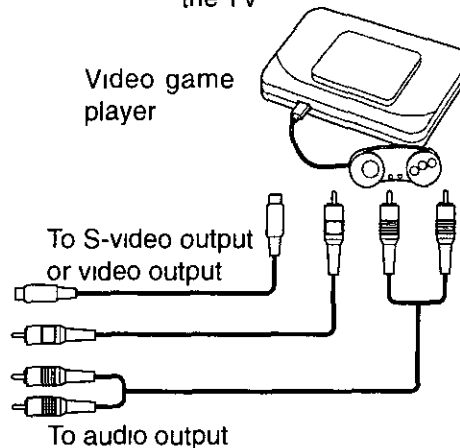

Confirming connections

Example When using the Video Input 4 terminal on the front of the TV



Turning on the TV and switching to game modes

1  Turn on the TV

2  Press the GAME button to switch to game mode

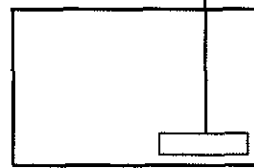

TV screen

- Displays the lapsed time
Lapsed time is displayed for 5 seconds every 30 minutes
Be sure to rest your eyes every 30 minutes

GAME [30] → **GAME [60]** → **GAME [90]**

The lapsed time display stops after 90 minutes

3 When finished, press the GAME button again (Turn off the game mode by switching input modes or changing the channel)

Notes.

- Video input mode can be changed when the GAME button is pressed
- Game mode is maintained when power to the TV is turned off
- When game mode is selected Picture will be set to PICTURE MENU (GAME), and sound will be set to SOUND MENU (GAME)

factory default setting

Item	Setting
Picture menu	Game
Audio menu	Game
Surround	ON
Screen mode	FULL

- Picture and sound can be set as desired (See page 34 and 36)

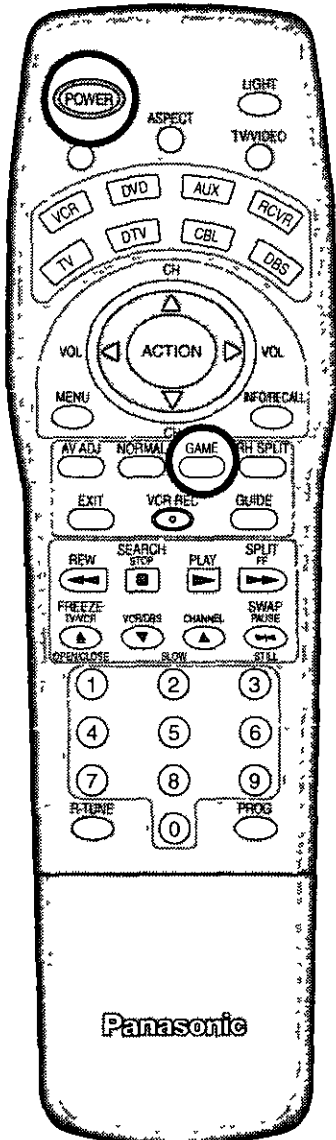

Recall / Mute

Recall (On-screen display)



Press this button to display channel number, off-timer remaining time, screen modes, and other settings. For approximately 10 seconds, only the channel number remains.

The channel number remains, but other information disappears after a specified period. Press this button again to delete channel number display.

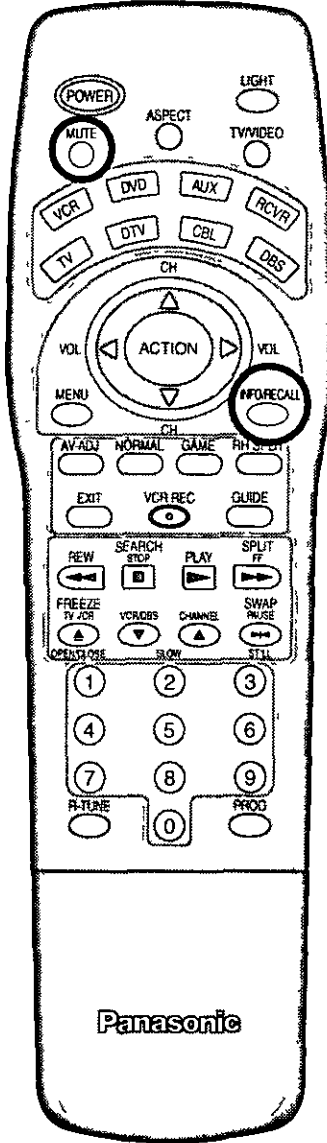

Full Information

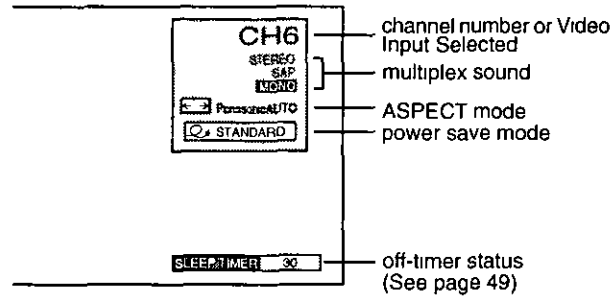

Channel number

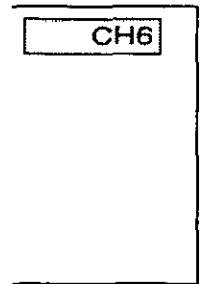

The INFO/RECALL button switches the display in the following order

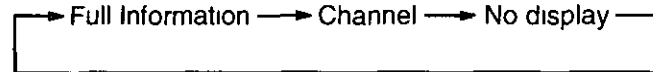

Mute

Useful when answering the phone or receiving unexpected visitors



Press this button to mute the sound. Press again to reactivate sound. Sound is also reactivated when power is turned off or volume level is changed.

Split screen

Split screen enables you to search other channels on the right screen or check video recording status

Splitting the screen

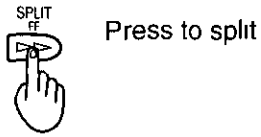

(The previously selected screen appears)

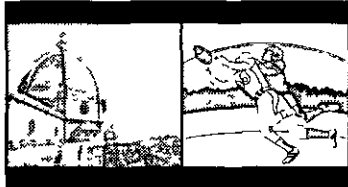

Example Two screen mode set to NORMAL aspect

- Returning to one screen

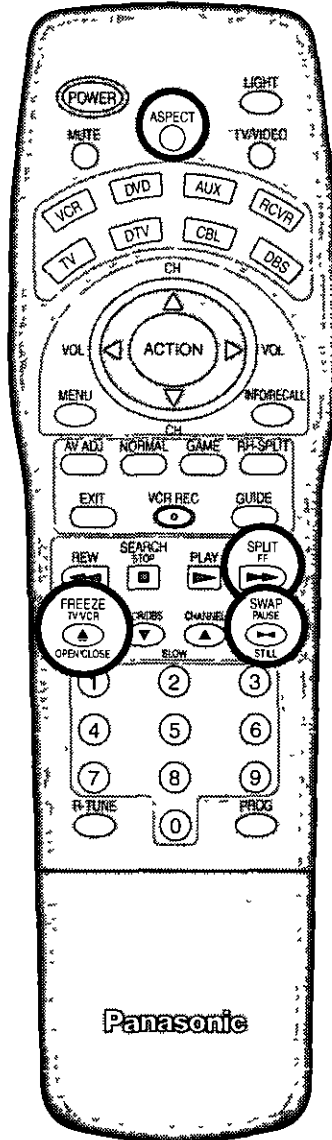
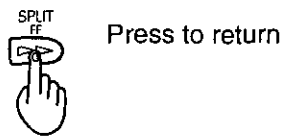

Selecting the screen mode for split screen.

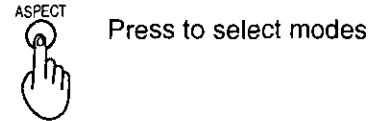

(FULL)

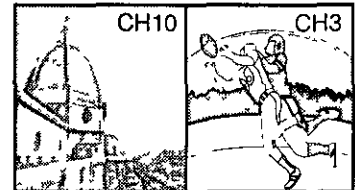

(NORMAL)

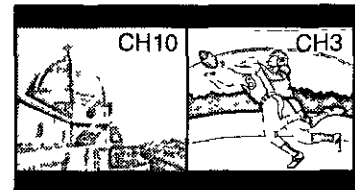

(PoutP)

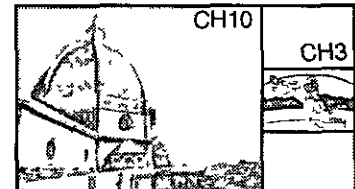

Freezing pictures

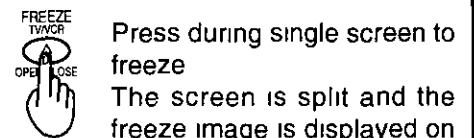

The screen is split and the freeze image is displayed on the right and the broadcast channel continues on the left

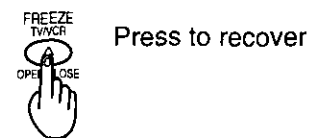

Notes.

- Sound from the left screen is output from the speakers on the TV set (EPJ) Sound from the right screen is output from the right earphone jack output on the front of the TV set (see page 13)
- When the screen is split, signals of the left screen are output from the rear monitor output terminal
- The left and right screen are processed by individual circuits and, therefore, may have slight variation in sound and image quality
- Split screen returns to single screen when the TV is turned off

Changing the channel of the right screen

during SPLIT SCREEN FULL, SPLIT SCREEN NORMAL, and PoutP.

1



Press to operate right screen.

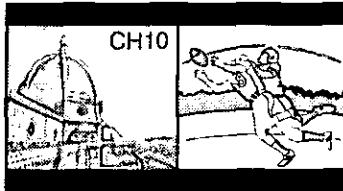

2



While is displayed on the screen, press to switch modes.



Example:
Change to channel 5.

Viewing videos



While is displayed on the screen, press to switch modes.

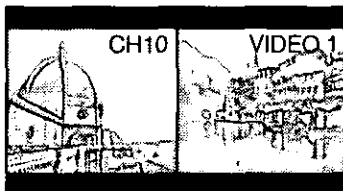

- The channels for the left screen can be changed in the same way as when the screen is single.

Swapping left and right screens



During SPLIT SCREEN FULL, SPLIT SCREEN NORMAL, PoutP: Press to swap.

Example: During SPLIT SCREEN NORMAL.

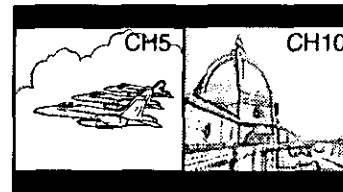
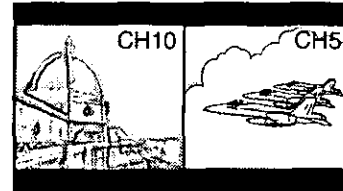

Screen mode names:

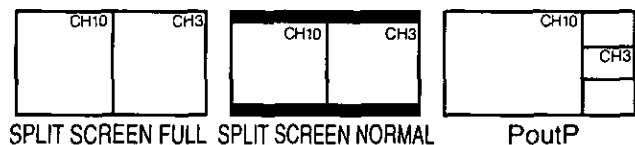

Notes:

- Use earphones to listen to sound of the right screen during SPLIT SCREEN FULL, SPLIT SCREEN NORMAL, and PoutP.
- The right and left screens cannot display the same picture at the same time.
- Use the right screen when playing video games on a split screen (to avoid distortion of images).

Adjusting screen position and size

Adjusting screen

1



Press to select the screen mode to adjust

2



Press to display the MENU screen

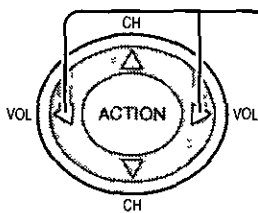

Press to select ADJUST menu

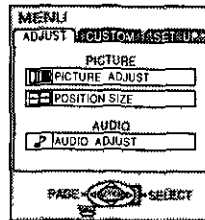

3

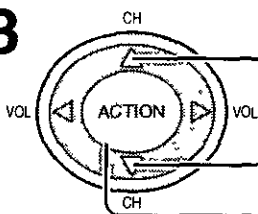

Press to select POSITION/SIZE and

press ACTION

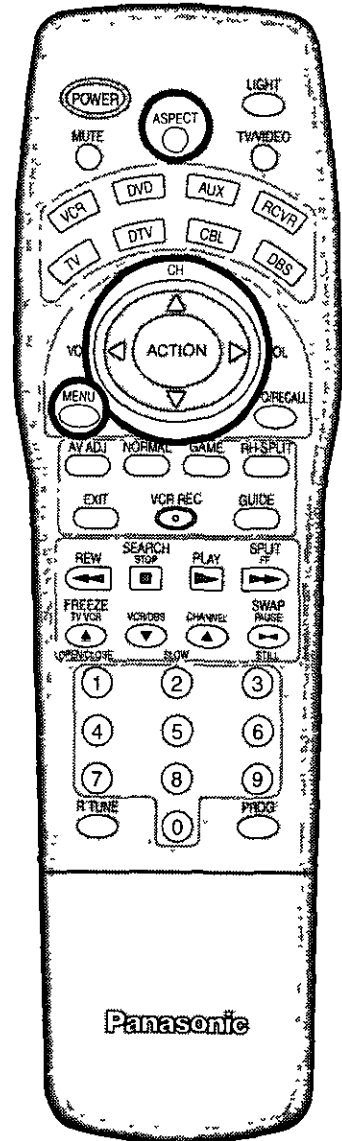

Notes:

- This TV is equipped with various screen modes. If a screen mode with a different aspect from the broadcast program is selected, image will appear differently. Select the proper screen mode with this in mind.
- Be careful when using this TV for commercial purposes or for public use, such as in cafes and hotels. Shrinking and enlarging images by using screen mode switching function (zoom, etc.) may violate copyright laws.
- Images displayed on a wide screen TV will be cut off or distorted at the edges, when viewing normal aspect images of 4:3 in ZOOM, JUST or FULL mode. Display in NORMAL mode to view the original image intended by the producer.
- For 1080i and 480p input images, screen position and size cannot be adjusted.
- The adjusted setting will be kept even when the TV is turned off.
- The signals output from the monitor output terminal on the back of the TV are not affected when the screen size and position are adjusted.

Switching screen width

During NORMAL mode, if noise appears on the ends of the image in SIZE 1, switch to SIZE 2

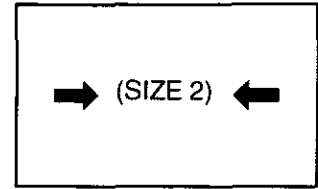
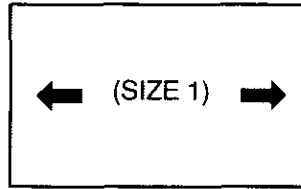
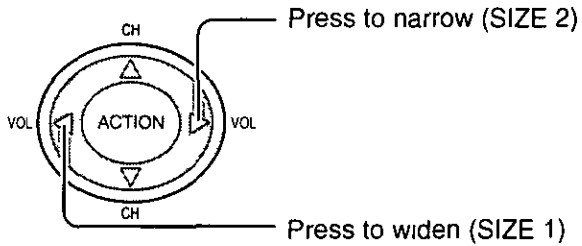

During JUST mode, if noise appears on the ends of the image in SIZE 1, switch to SIZE 2

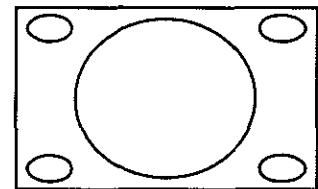
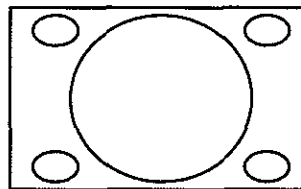
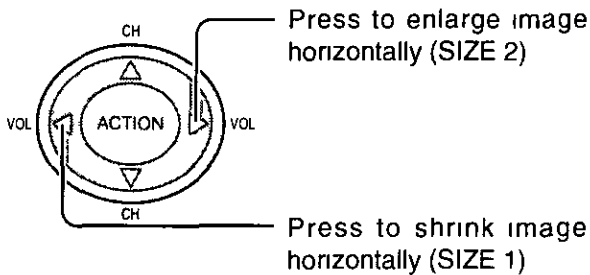

(SIZE 1)

(SIZE 2)

- To return to standard → ACTION
- To end adjustments → MENU (EXIT)

Changing vertical size

During ZOOM modes

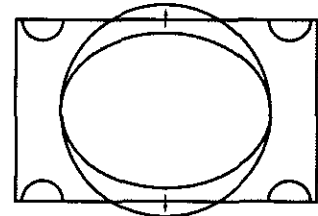
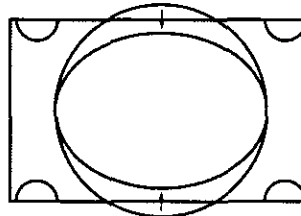
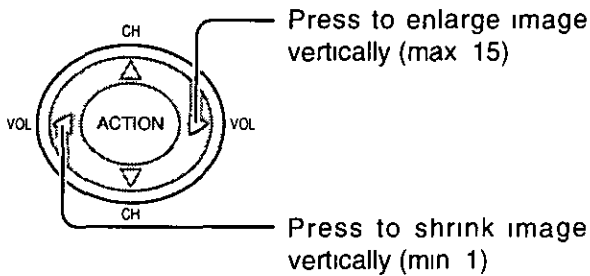

- To return to standard → ACTION
- To end adjustments → MENU (EXIT)

Displaying images cut off from the screen

For ZOOM and JUST modes

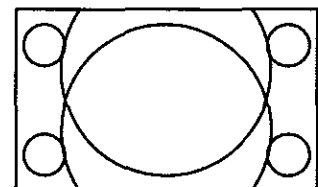
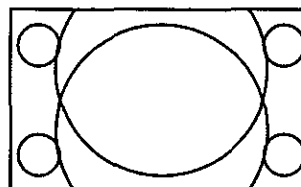
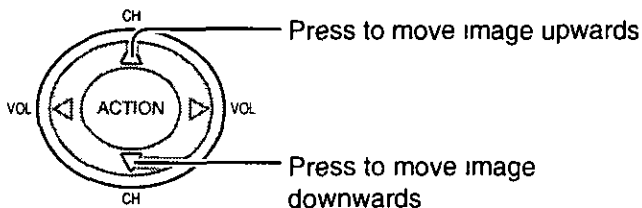

- To return to standard → ACTION
- To end adjustments → MENU (EXIT)

Audio Adjustments

1 Press the MENU button to display the MENU screen and select ADJUST

2 Select AUDIO ADJUST of ADJUST from the MENU screen

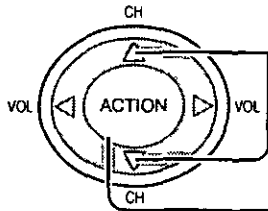

Press to select AUDIO ADJUST

Press to display AUDIO ADJUST screen

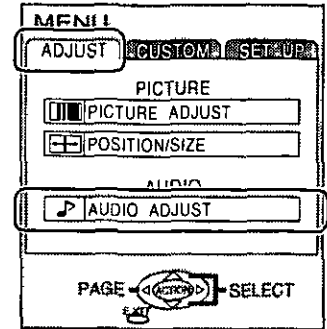

3 Press to select the menu to adjust each item

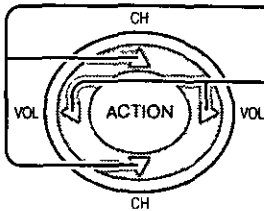

Select the desired level by listening to the sound

BASS

Adjusts low sounds

TREBLE

Adjusts high sounds

BALANCE

Adjust left and right volumes

SURROUND

To enjoy a concert hall effect, turn SURROUND to ON
During stereo sound or soft playing

SURROUND OFF ON

During monaural sound

SURROUND OFF ON

AFB (Acoustic Feed Back)

Enables speakers to produce the best quality sound (Normally turned on)

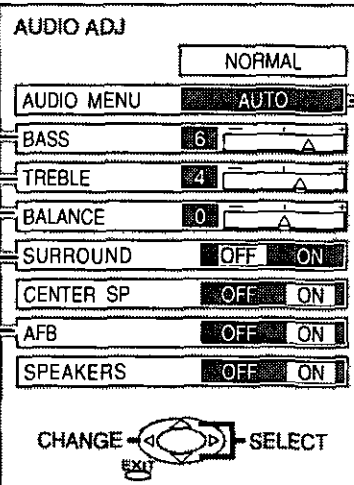

AUTO

Automatically adjusts quiet sound and loud sound for ease of listening

STANDARD

Emits the original sound

DYNAMIC

Gives contrast to sound

MUSIC 1

For programs consisting mainly of music Enhances high sounds (around 4 kHz)

MUSIC 2

Enhances high sounds even more (Recommended for those who have slight hearing deficiencies)

When GAME is selected for the picture, sound setting also changes to GAME
During GAME mode, sound mode cannot be changed in this menu

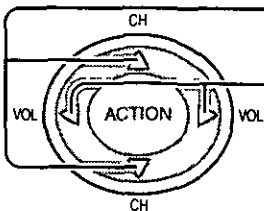

To reset to standard setting,

select NORMALIZE with the up ▲ and down ▼ buttons and press ACTION

To adjust settings individually, press the AV ADJUST button to select the desired menu and adjust using the left ◀ and ▶ right buttons

● To end adjustments →

MENU



Press MENU button

Turning the center speaker ON and OFF to enhance the mood

During AUDIO ADJUST menu

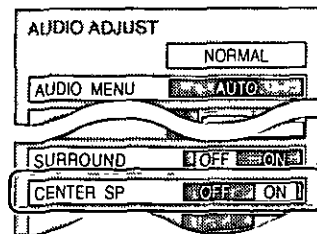
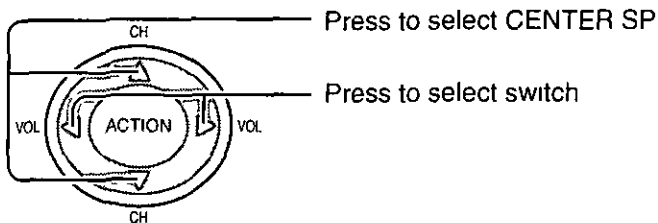

- ON ● Sound given off from the center is enhanced and stability is increased
- OFF ● Use when certain scenes are hard to hear or to enhance and increase stability

Turning the speaker sound ON and OFF

SPEAKERS OFF

Turns off the speaker sound

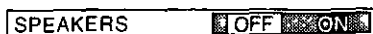

Notes

- Sound signals are output from the rear AUDIO OUT terminal
- When volume is adjusted or the mute button is pressed from the remote control, a message will be displayed
- Sound signals from the headphone and earphone jacks are as follows
HPJ OFF
EPJ ON

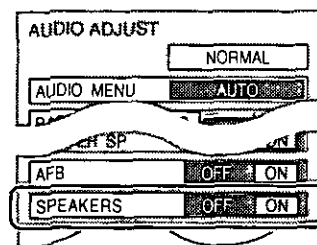

SPEAKERS ON

Speaker sound is normal



- To end adjustments →

By pressing the AV-ADJ button on the remote control, PICTURE ADJUST and AUDIO ADJUST can be directly adjusted instead of starting from the MAIN menu

AV ADJ → The selected menu will change each time the AV-ADJ button is pressed (press until the desired menu is displayed)

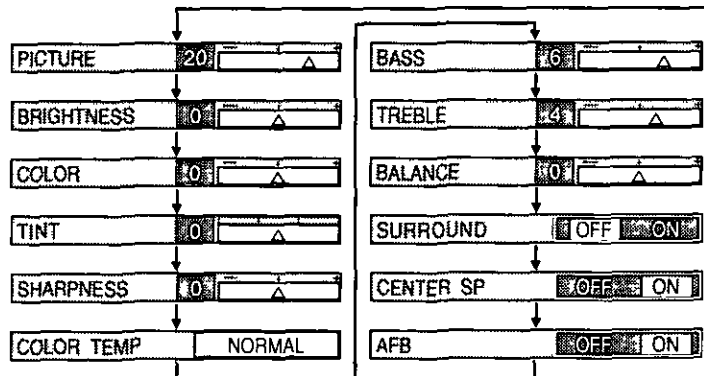
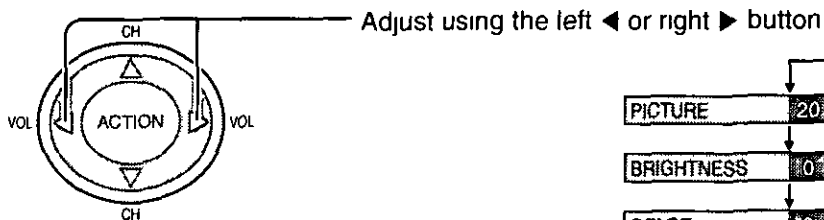

Picture Adjustments

1 Press the MENU button to display the MENU screen and select ADJUST

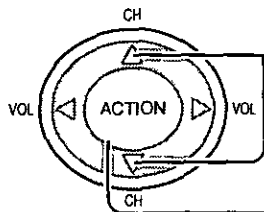

Press to select to PICTURE ADJUST

Press to display the PICTURE ADJUST screen

NORMAL is displayed at default

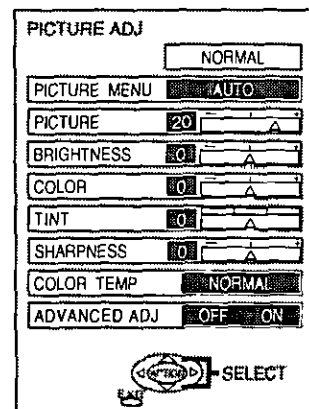
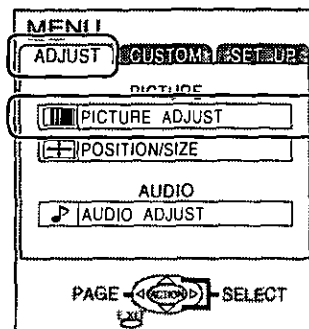

2

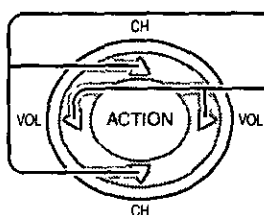

Press to select the menu to adjust

Select the desired level by looking at the picture behind the menu

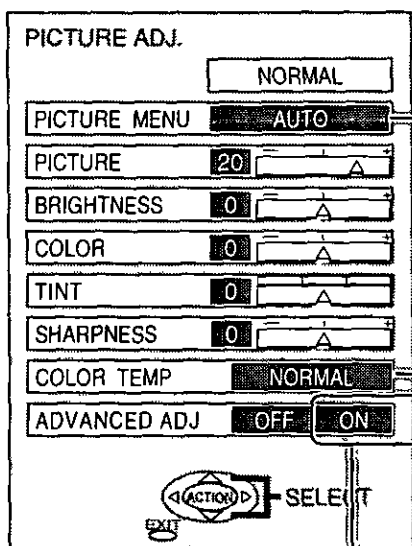

Adjusts picture in more detail (see page 38)

Press the left ◀ or right ▶ button to switch between modes

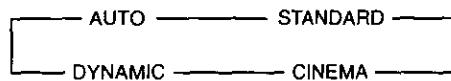

- AUTO**
Adjusts brightness, depending on surrounding light, for easier viewing
- STANDARD**
Displays unaltered image
- CINEMA**
Ideal for movies
- DYNAMIC**
Displays a clear screen with contrast of light and dark

During GAME mode, picture mode cannot be changed in this menu

Press the left ◀ or right ▶ button to switch between modes

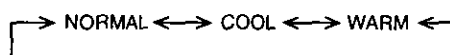

Picture Adjustments

PICTURE
Selects proper brightness and density for the room

BRIGHTNESS
Adjusts for easier viewing of dark pictures such as night scenes and hair

COLOR
Adjusts slightly to a lighter color

TINT
Adjust for nice skin color

SHARPNESS
Displays a sharp image

PICTURE ADJ

NORMAL

PICTURE MENU AUTO

PICTURE 20

BRIGHTNESS 0

COLOR 0

TINT 0

SHARPNESS 0

COLOR TEMP NORMAL

ADVANCED ADJ OFF ON

ACTION
SELECT

ADVANCED ADJ
This function is available when STANDARD or CINEMA mode is selected for the PICTURE MENU

ADVANCED ADJ ON
Enables fine picture adjustment at a professional level (see next page)

ADVANCED ADJ OFF
Displays images with the selected setting of the PICTURE MENU

- To adjust each item, →

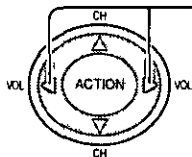

Press the up ▲ and down ▼ button and make adjustments using the left ◀ and ▶ right buttons

- To reset to standard setting, →

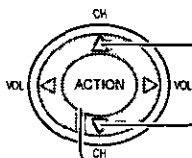

Select NORMALIZE with the up ▲ and down ▼ buttons

Press ACTION

- To return to normal viewing →



Press MENU button

By pressing the AV-ADJ button on the remote control, PICTURE ADJUST and AUDIO ADJUST can be directly adjusted instead of starting from the MAIN menu (See page 35)



The selected menu will change each time the AV-ADJ button is pressed (press until the desired menu is displayed)

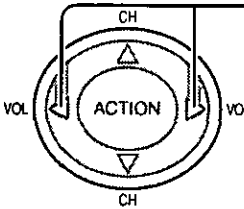

Adjust using the left ◀ or right ▶ button

Note:
There is little change when PICTURE is increased with a bright picture or reduced with a dark picture

Picture Adjustments

Press left ◀ or right ▶ to turn ON, and a ▶ mark is displayed
 Press down ▼ to display the ADVANCED ADJUST screen

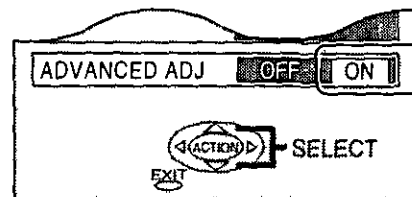

ADVANCED PICTURE ADJUST

During STANDARD or CINEMA mode, ADVANCED ADJUST setting is possible

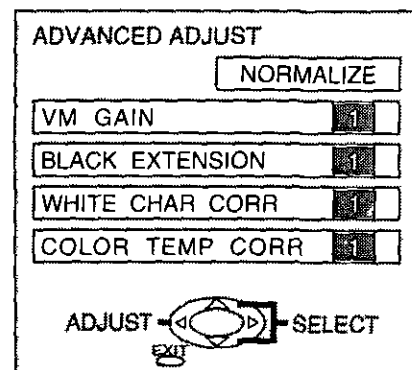
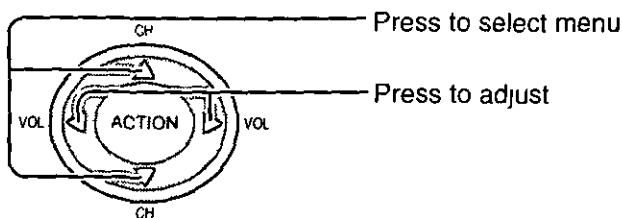

- To return to normal viewing →

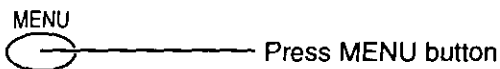

- To return to PICTURE ADJUST menu →

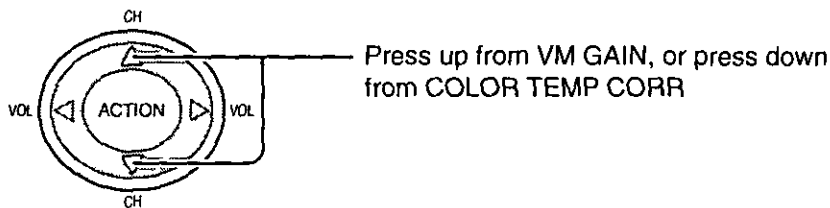

- To return to standard →

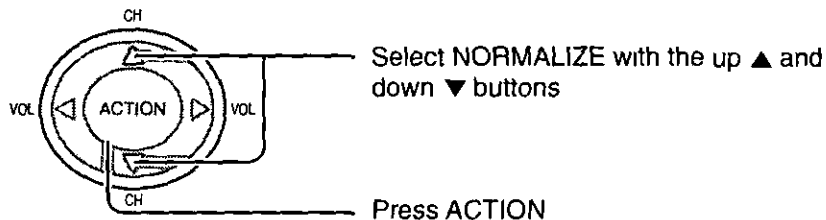

Item	Content	Adjustable range
VM GAIN	Adjusts the emphasis for the Vertical contours	0 (no adjustments) - 15 (max adjustment)
BLACK EXTENSION	Adjusts the dark shades of the image in gradation	
WHITE CHAR CORR	Emphasizes the whiteness of parts such as white characters	
COLOR TEMP CORR	Fine adjustments of color temperature selected for each PICTURE MENU mode	-7 (low color temperature) - 7 (high color temperature) <reddish color> <bluish color>

Playing special video software

When playing special images such as three dimensional video disks on video disk players or game software on video game players, use GAME mode Use TV mode for normal viewing

Selecting VIDEO menu

Press the MENU button to display the MENU screen and select SETUP

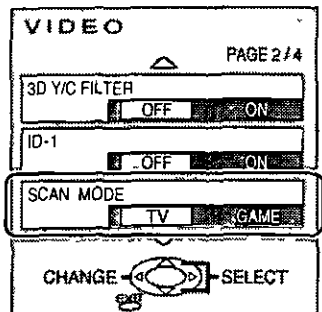
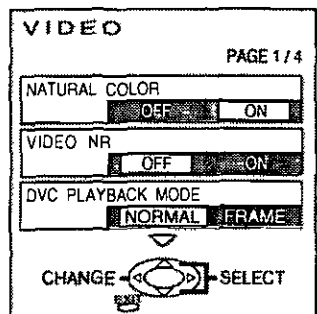
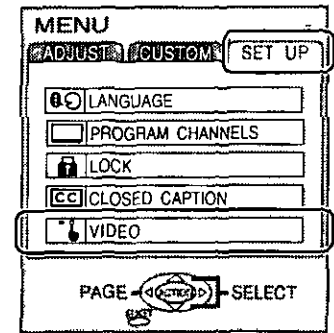
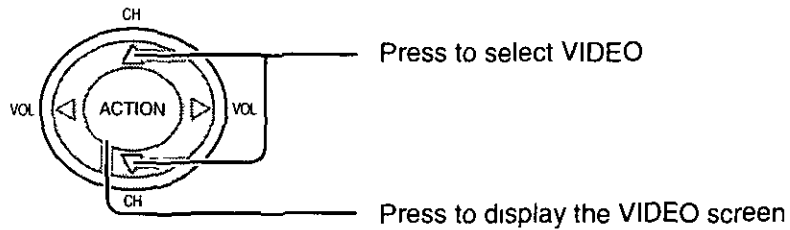

Switching to SCAN MODE.

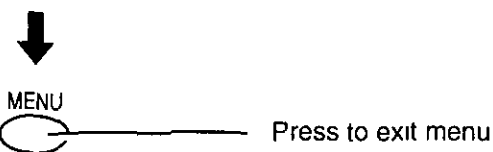
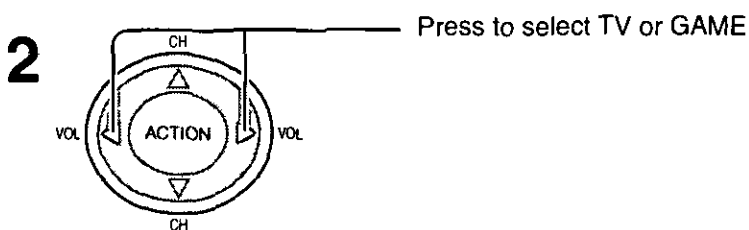
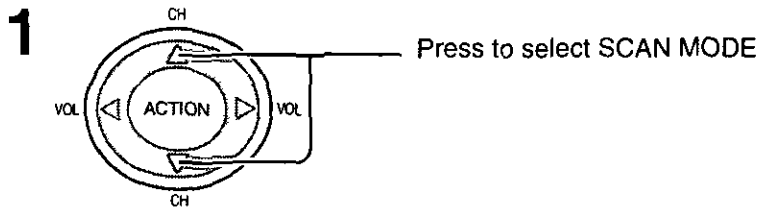

Notes.

- The VIDEO set up screen is made up of 4 pages
Use the up ▲ and down ▼ buttons to change pages

Closed Captions

This receiver has a built in decoder that provides a visual depiction of the audio portion of a television program in the form of written words across the screen (white or colored letters on a black background). It allows the viewer to read the dialogue of a television program or other information.

- 1** Press the MENU button to display the MENU screen and select SETUP

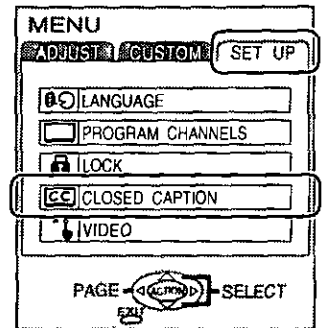
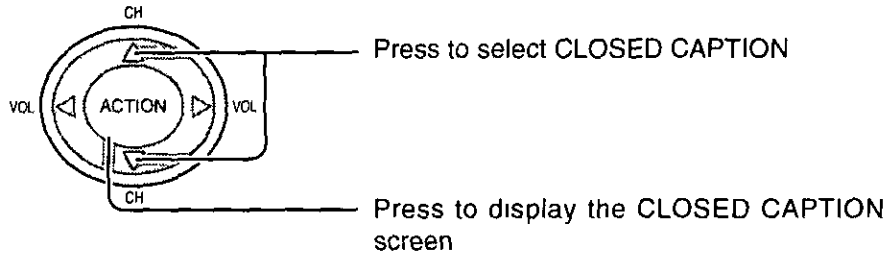

2 **CC** On Mute

Activates the On-Screen Closed Caption feature, when the MUTE button on the Remote Control is pressed. To deactivate, press the MUTE button again.

Note:

This feature functions when the Closed Caption Mode is in the "OFF" position. The program being viewed must be broadcast with Closed Caption.

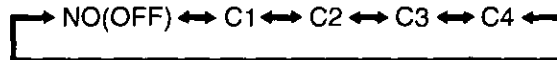
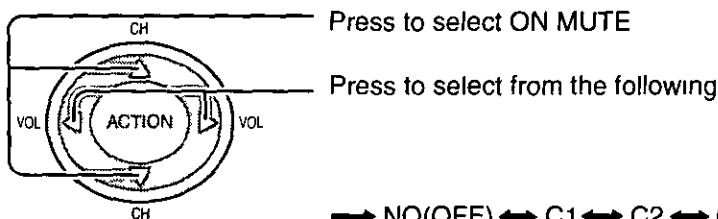
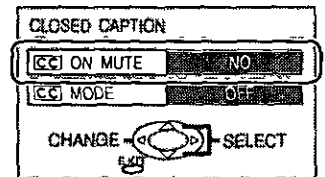

Notes

- Recommended menu Set Up for Closed Caption when using Mute Button
 CC ON MUTE C1
 CC MODE OFF
- The setting for CC ON MUTE is valid only when the CC MODE is OFF, CC MODE set to ON will override CC ON MUTE
 This menu cannot be selected when the MAIN picture is displaying a COMPONENT VIDEO INPUT of 480i or more
- When aspect is ZOOM, Closed Caption cannot be used

3 **CC** Mode

Activates the On-Screen Closed Caption feature. When activated this feature will remain on until OFF is selected in this menu.

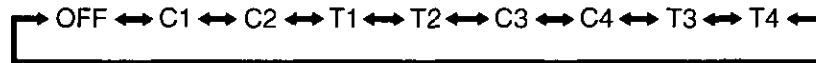
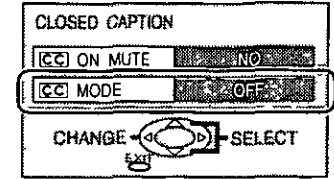
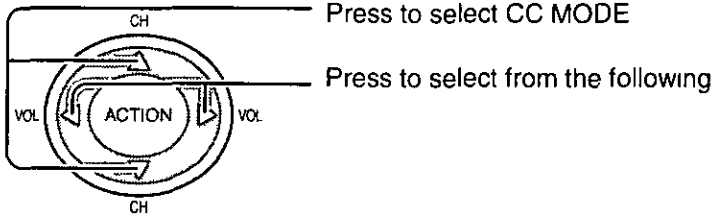

- **CAPTION OFF** - Recommended mode when Closed Caption is not being used
- **CAPTION C1** - For video related information that can be displayed (up to 4 lines of script strategically placed on the television screen so that it does not obstruct relevant parts of the picture)
- **CAPTION C2** - Another mode used for video related information
- **TEXT T1** - Blanks out a large portion of the picture on the television screen, and displays program guide or any other information currently being transmitted
- **TEXT T2** - Another mode which displays information and blanks out a large portion of the picture on the television screen
- **CAPTION C3** - Another mode used for video related information
- **CAPTION C4** - Another mode used for video related information
- **TEXT T3** - Another mode which displays information and blanks out a large portion of the picture on the television screen
- **TEXT T4** - Another mode which displays information and blanks out a large portion of the picture on the television screen

- To end adjustments →  Press MENU button

Lock Feature

In the United States and Canada, the V-CHIP consists of two rating systems, which are MPA (MOTION PICTURE) and TV PARENTAL GUIDELINES. Its function is to block programs by the rating data in the XDS data packets sent from broadcasting stations. The user can select which rating programs should be blocked by using the LOCK MENU options.

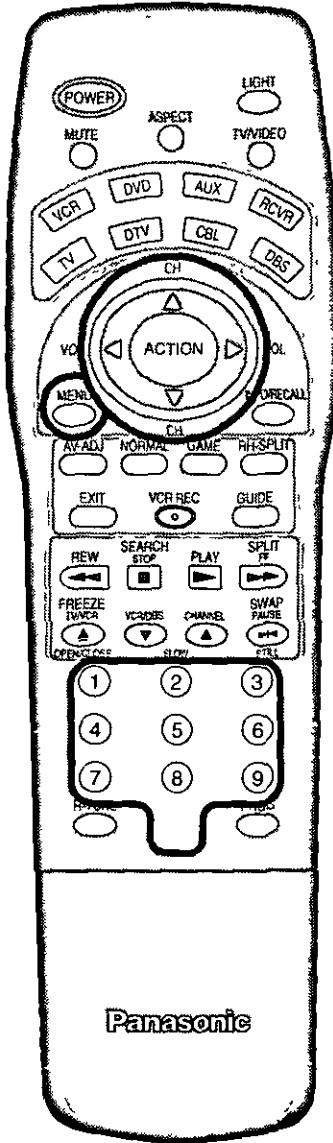

Press the MENU button to display the MENU screen and select SETUP

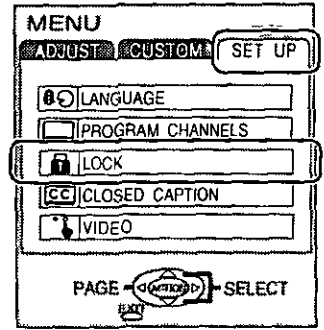
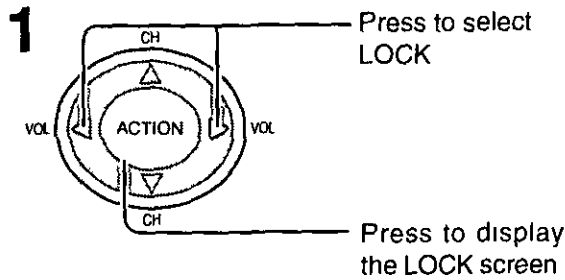

Input code
Enter any 4-digit number as a password
These numbers will be needed when
deactivating the LOCK function

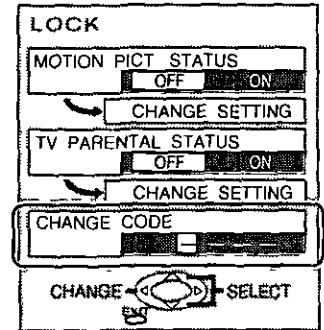
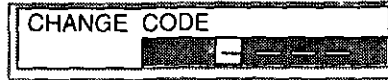

Note:
Use a code that is easy to remember or record it in a safe place

2 Selecting broadcasts to lock

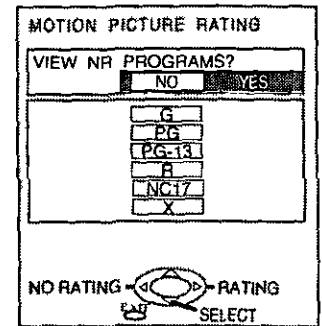
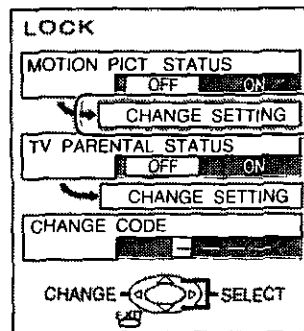
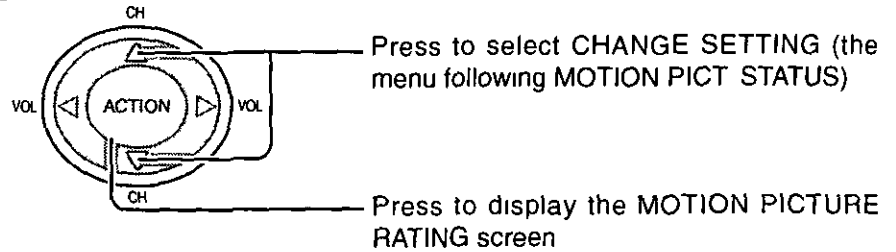

3

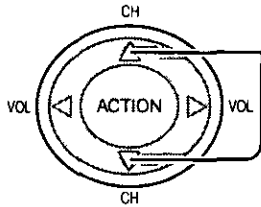

Press to select rating to lock

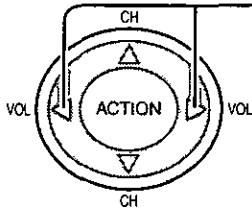

Press to select YES or NO



Press to return to LOCK screen

Rating (turns red when on)

G General audience

PG Parental guidance suggested

PG-13 Parental guidance needed under 13 years old

R Restricted

NC17 No one under 17 is admitted

X Pornography

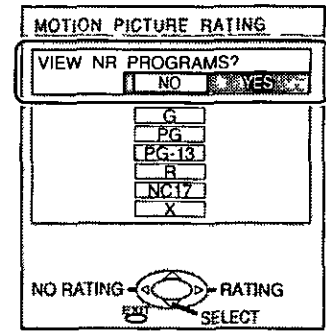

4

Setting MOTION PICT STATUS

Locking and unlocking the ratings selected above

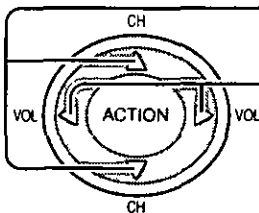

Press to select MOTION PICT STATUS

Press to select ON or OFF



Press to set

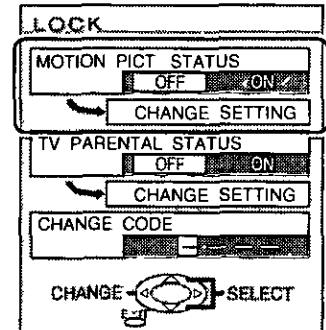

ON The broadcasts selected in the MOTION PICTURE RATING menu cannot be viewed

OFF LOCK is deactivated and any broadcast, regardless of the setting for MOTION PICTURE RATING, can be viewed

Lock Feature

TV PARENTAL STATUS

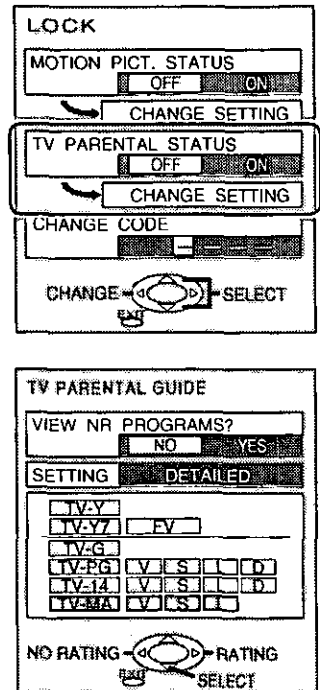
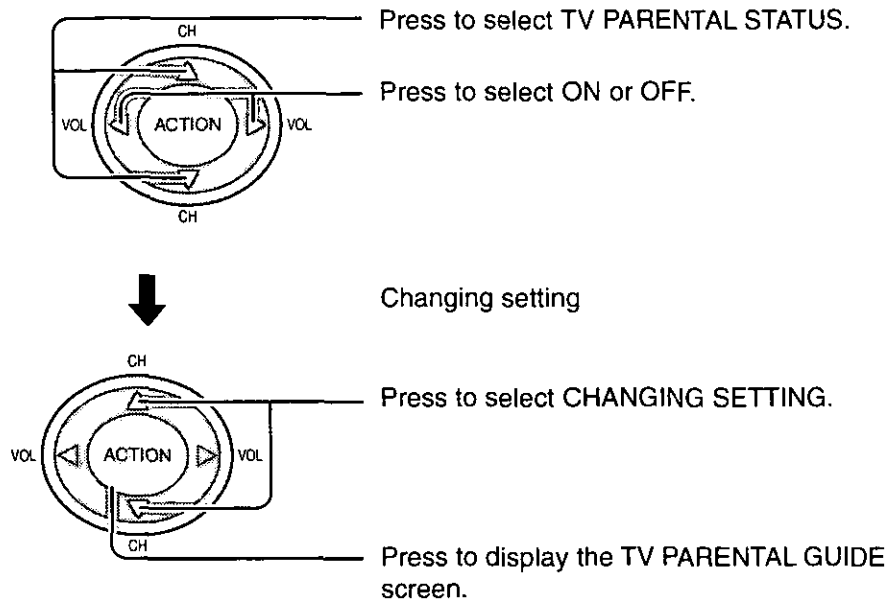

Setting the TV PARENTAL PROGRAMS screen

VIEW NR PROGRAMS?

NO : The broadcasts selected in the MOTION PICTURE RATING menu cannot be viewed.

YES: LOCK is deactivated and any broadcast, regardless of the setting for MOTION PICTURE RATING, can be viewed.

SETTING

BASIC: The up ▲ and down ▼ buttons change the selected title.

DETAILED: The cursor selecting the title can be moved to select options displayed on the right. The down ▼ button moves the cursor to the right if options are available. The up ▲ button moves the cursor to the left and if there are no options to the left, the cursor will move up.

Locking and unlocking

- When a title field is selected, all ratings below this rating are selected.
- When options within an option field are selected, ratings below this rating within the same field are selected.
- Ratings displayed in green are unlocked and those displayed in red are blocked programs.

1. Ratings for children: These ratings are divided into ranks as follows.

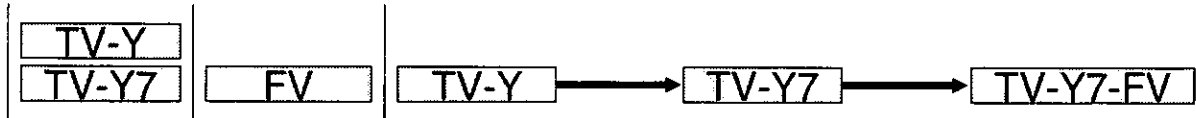

2. Ratings for teenagers: These ratings are the same as the matrix system. This system is described in the diagram below.

Ratings for all ages are on top and ratings for adults are on the bottom.

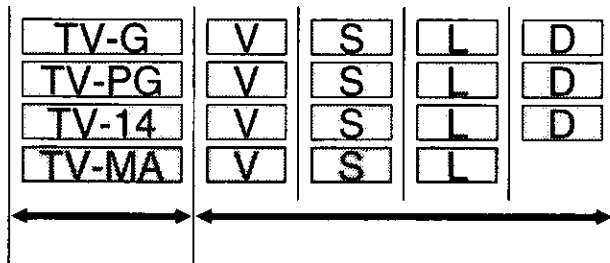

- To end adjustments →  Press MENU button.

Customizing the VIDEO INPUT labels

Display for each VIDEO INPUT can be changed to match with the connected device (VCR, video games).

Example: When changing VIDEO 3 to LD.

- 1** Press the MENU button to display the MENU screen and select SETUP.

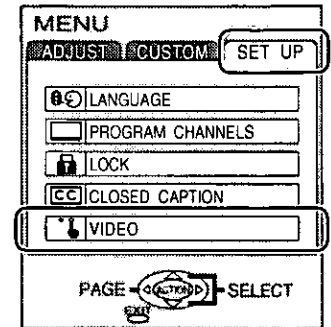
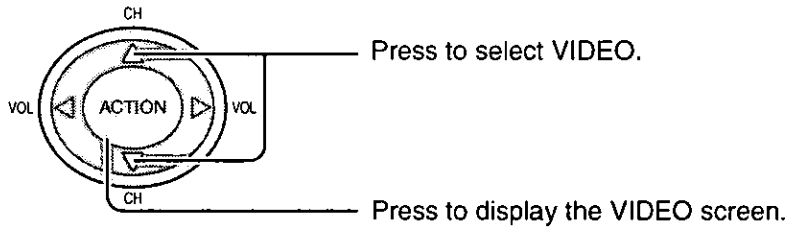

- 2** Press to select VIDEO INPUT LABEL.
- Press to display the VIDEO INPUT LABEL screen.

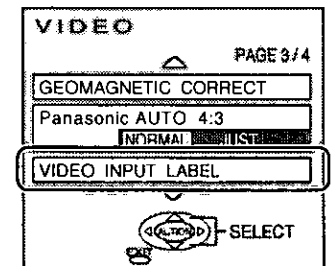
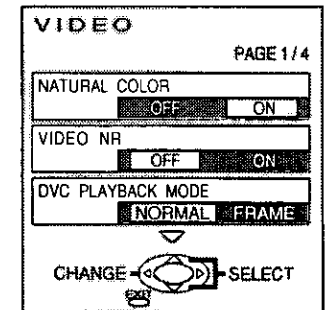
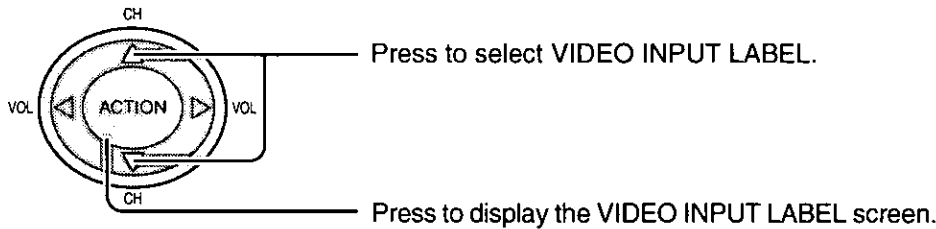

Note:

The VIDEO screen consists of 4 pages.
Use the up ▲ and down ▼ buttons to change pages.

Customizing the VIDEO INPUT labels

3

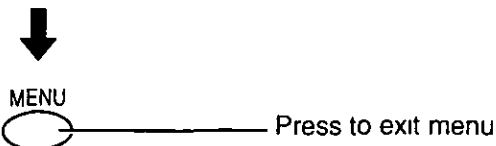
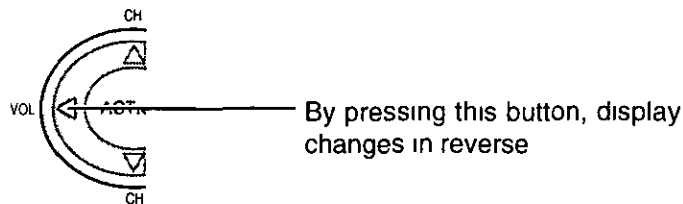
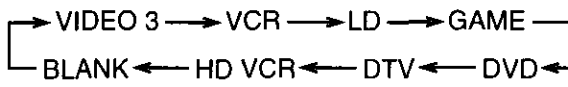
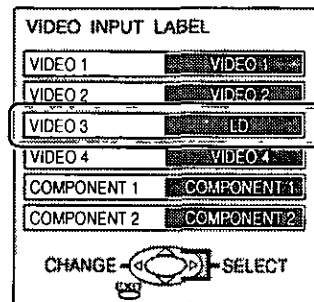
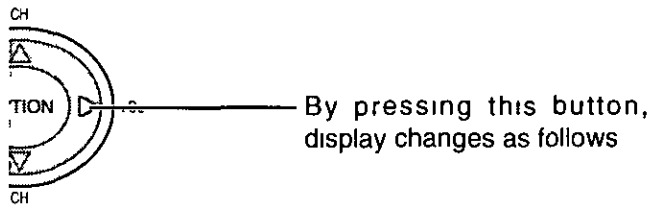
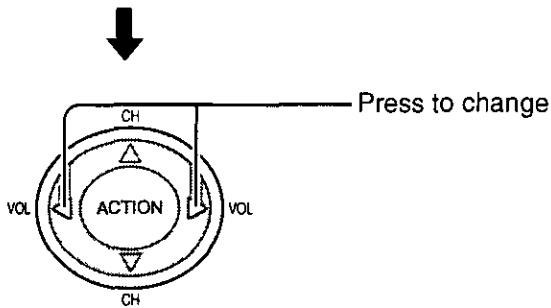
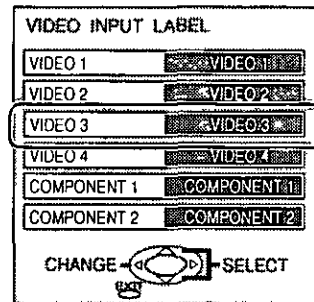
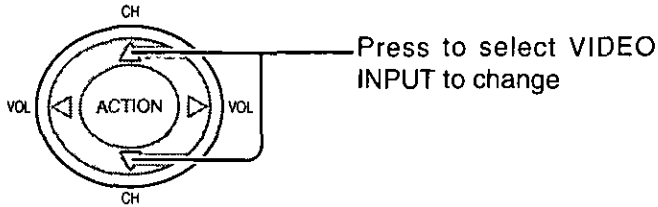

Note

When DVD or DTV is selected for the change, images are adjusted to match each input signal

Selecting STEREO/SAP/MONO

Press the MENU button to display the MENU screen and select CUSTOM

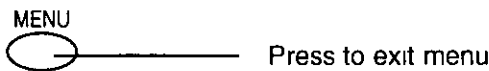
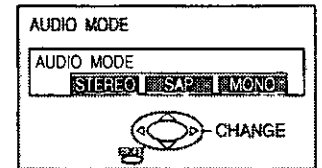
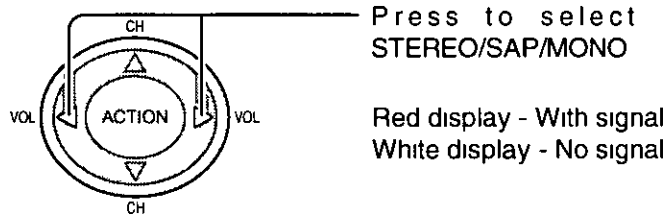
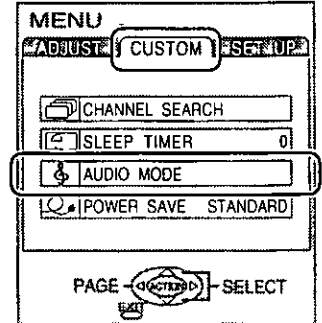
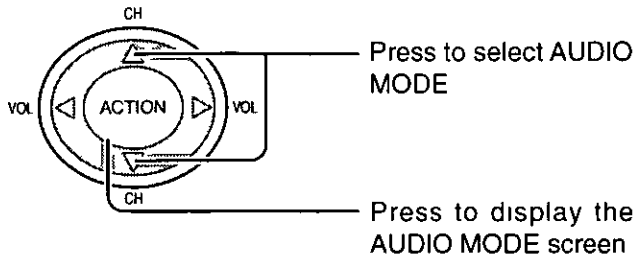

Helpful Hints:

- **STEREO** - Two channel Audio reception
- **SAP** - Second Audio Programming (typically used for bilingual audio)
- **MONO** - Use when stereo signal is weak

Using the off-timer

1



Press the MENU button to display the MENU screen.

2

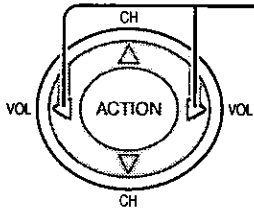

Press the left "◀" or right "▶" button to select CUSTOM.

3

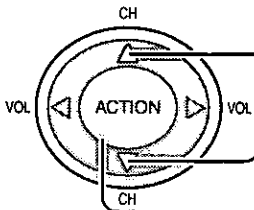

Press the up "▲" or down "▼" button to select SLEEP TIMER.

Press to displayed SLEEP TIMER adjust screen.

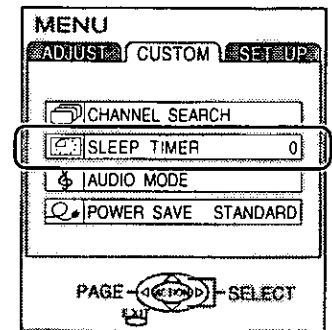

4

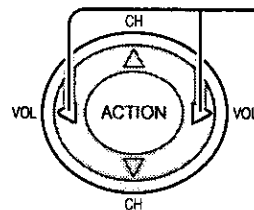

Press the left "◀" or right "▶" button and select the desired sleep time from [→0↔30↔60↔90←] minutes to select times.

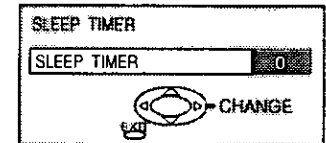

Notes:

- When the power to the TV set is disrupted due to a power outage or similar problem, after power is restored, the off-timer will be deactivated and the TV will be in standby mode.
- To see the remaining sleep time, press the INFO/RECALL button.

Viewing with reduced brightness (POWER SAVE)

Selecting the POWER SAVE menu

Press the MENU button to display the MENU screen and select CUSTOM.

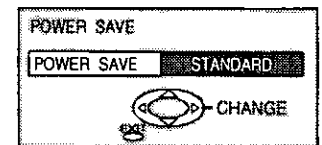
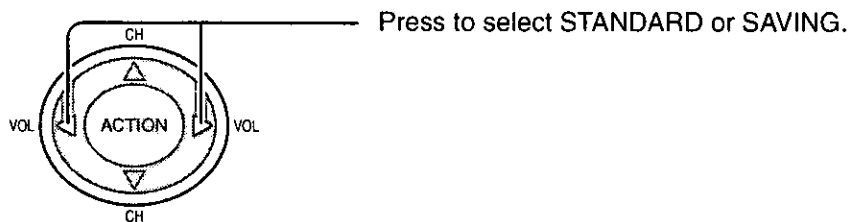
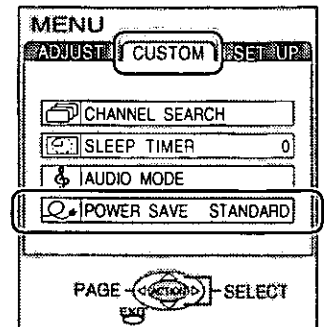
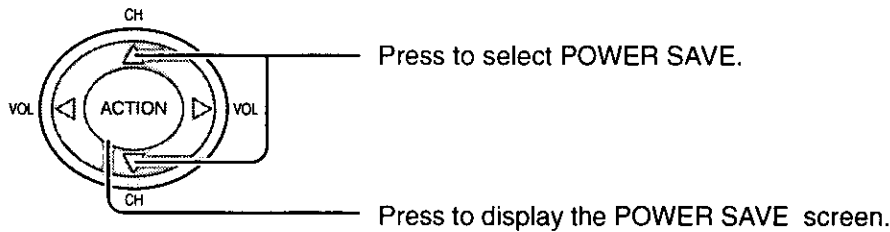

By reducing the brightness of the brightest scenes, a natural image is achieved and reduces power consumption at the same time.



Viewing in the selected PICTURE menu setting or in your preferred brightness level is possible.

Notes:

- When CINEMA or GAME mode is selected for the image menu, POWER SAVE does not function.
- The setting for POWER SAVE is set even when the TV is turned off .

Optimizing display for DVC recording mode (DVC PLAYBACK MODE)

When digital video camera recording is in FRAME, images will have high resolution.

1 Press the MENU button to display the MENU screen and select SETUP

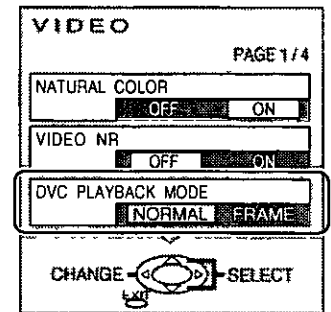
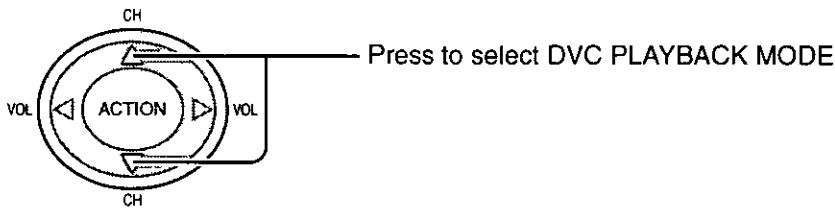
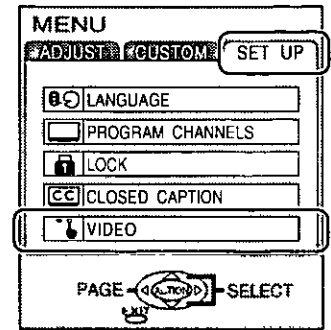
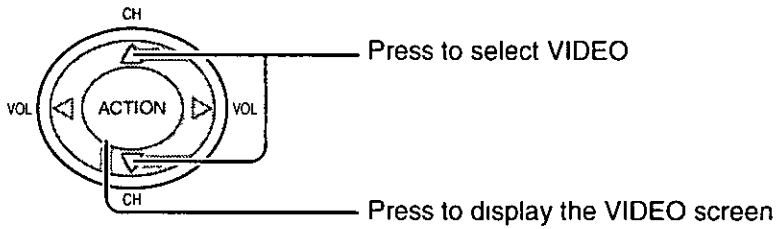

2 Press to set

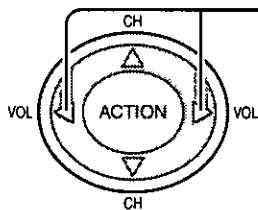

NORMAL When playing normal images
 FRAME When displaying FRAME recording mode

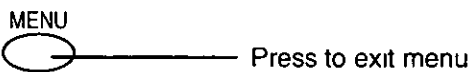

Note

- Switches only during VIDEO INPUT 1-4 or GAME modes
- If normal images are viewed in FRAME mode, moving pictures may appear awkward Switch to NORMAL
- The VIDEO screen consists of 4 pages
- Use the up ▲ and down ▼ buttons to change pages

Adjusting unnatural video images (3D Y/C FILTER)

Selecting the VIDEO menu

Press the MENU button to display the MENU screen and select SETUP.

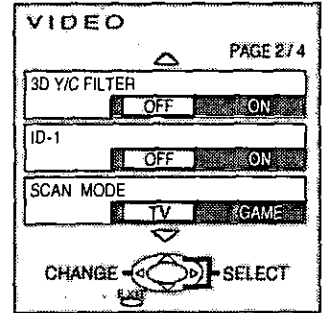
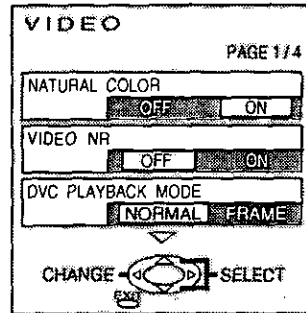
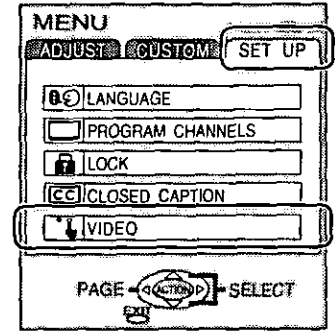
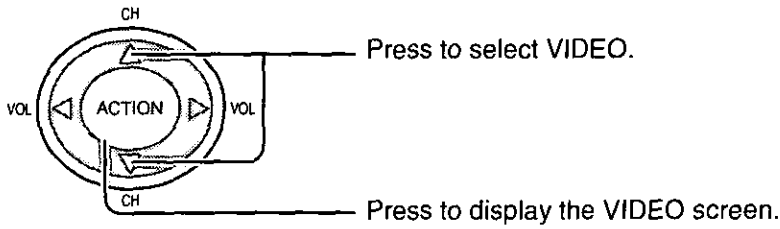

Switching to 3D Y/C FILTER

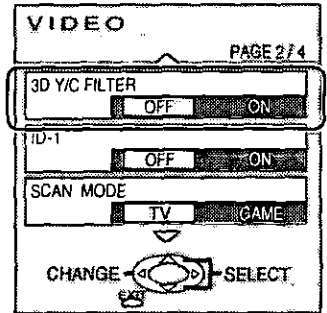
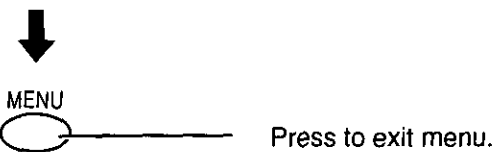
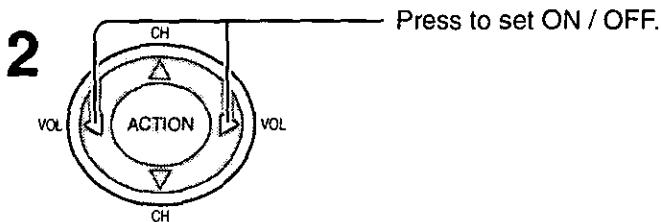
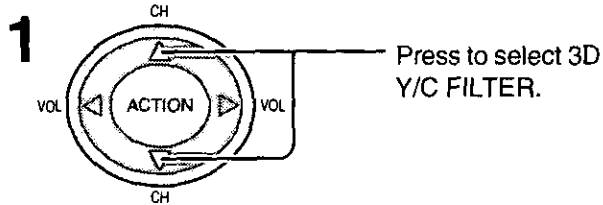

Notes:

- The VIDEO menu is made up of 4 pages.
 Use the up ▲ and down ▼ buttons to change pages.
- Not available for COMPONENT VIDEO 1-2.

Cancelling automatic enlarging of screen

Used for viewing 4:3 images in Panasonic auto mode. (See page 22)

1 Press the MENU button to display the MENU screen and select SETUP

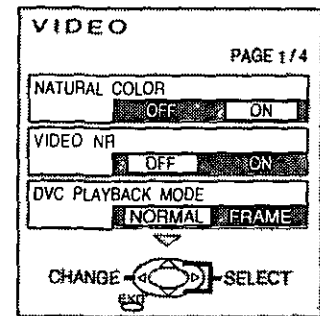
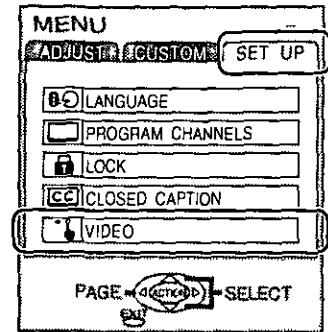
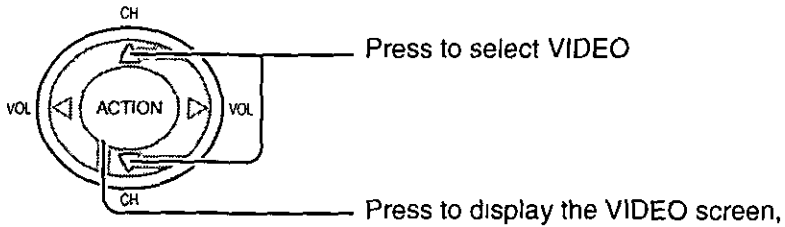

2 Press to display PAGE 3/4 and select Panasonic AUTO

Press to select NORMAL

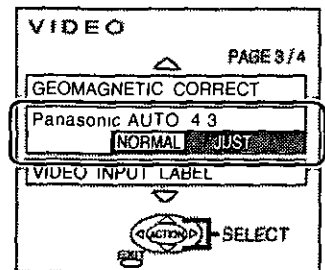
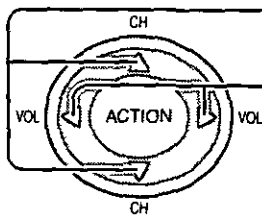

Displays NORMAL screen for 4 3 images
Displays JUST screen for 4 3 images

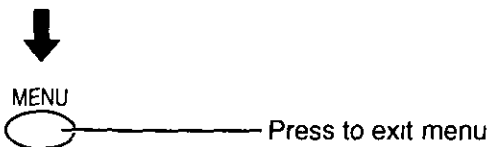

Note.
The VIDEO screen consists of 4 pages
Use the up ▲ and down ▼ buttons to change pages

Setting when 480p signals (sequential scan) are input through COMPONENT VIDEO INPUT

Displays input signals (480p signals) in a natural color from digital equipment adaptors connected to COMPONENT VIDEO INPUT (Y, Pb/Cb, Pr/Cr input terminals).

1 Press the MENU button to display the MENU screen and select SETUP

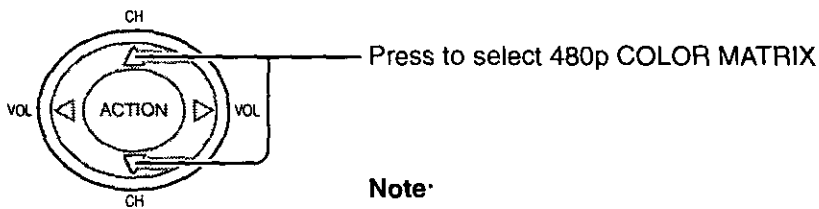
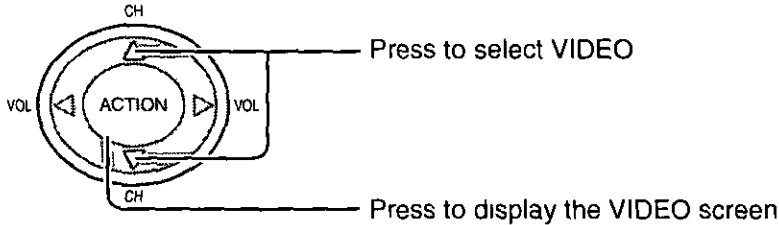

Note:
Use the up ▲ and down ▼ buttons to change pages

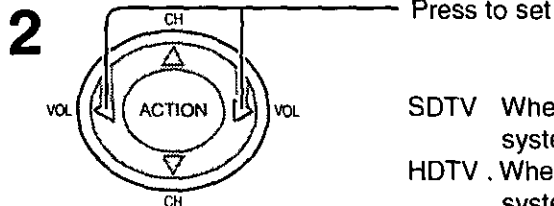
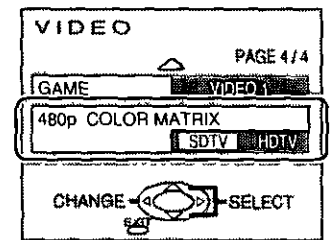
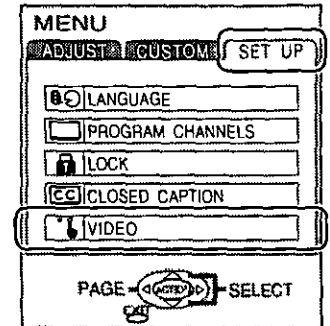

SDTV When the input signal is a normal TV system (NTSC)
HDTV . When the input signal is a Hi-Definition system (HD)

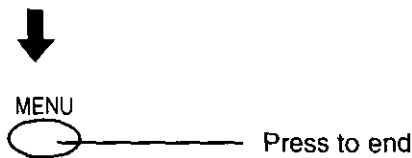

Note.

480p COLOR MATRIX does not need to be set when using Hi-Definition equipment or 480i output equipment

Geomagnetic correction (Adjusting skewing of images)

This correction is made when moving the TV set or when image is slightly skewing.

1 Press the MENU button to display the MENU screen and select SETUP.

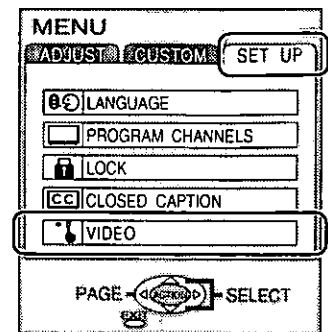
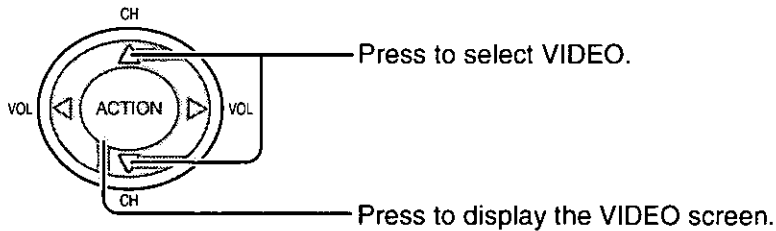

2 Press to display PAGE 3/4 and select GEOMAGNETIC CORRECT.

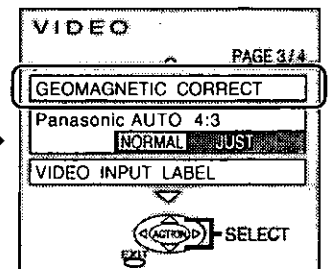
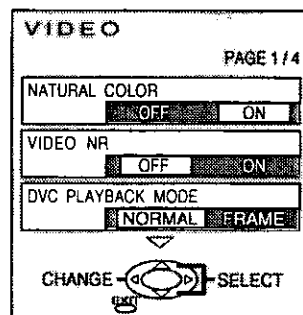
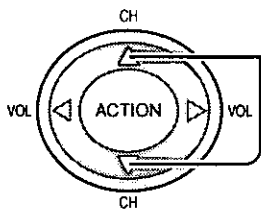

3 Press to display the GEOMAGNETIC CORRECT screen.

Adjust so that the bar is horizontal.

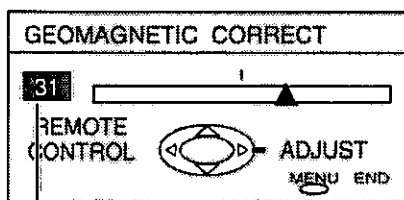
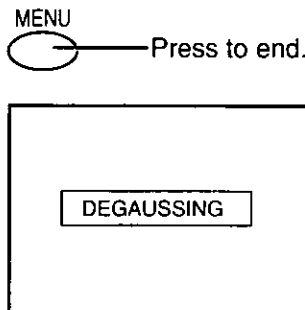
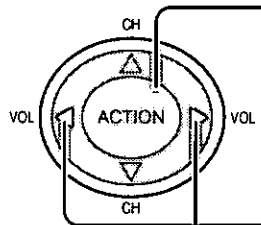

Screen direction	Approximate adjusting amount
North	approx. 10
East/West	approx. 31
South	approx. 50

- The "DEGAUSSING" message is displayed after a clicking sound is heard. (The screen will be distorted momentarily.)
- The display will disappear and another clicking sound will be heard. (End of adjustment)

Approx. 5 seconds later

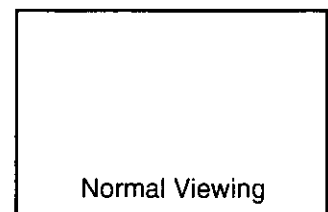

Note:
The VIDEO screen consists of 4 pages.

Switching languages for display

1 Press the MENU button to display the MENU screen and select SETUP.

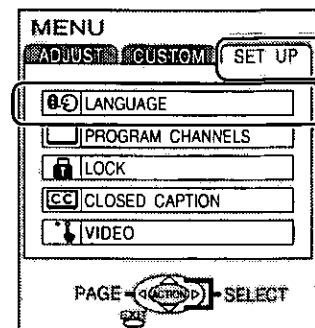
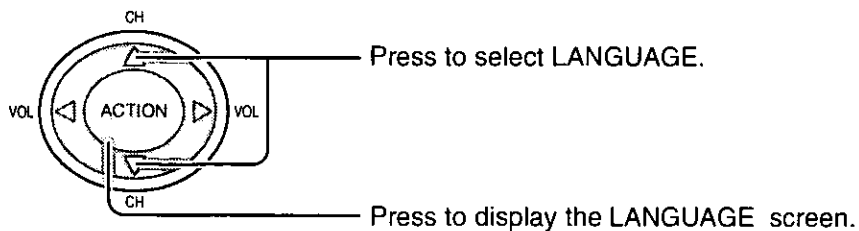

2 Press to select preferred language.

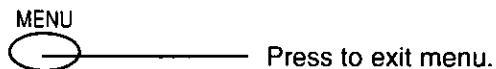
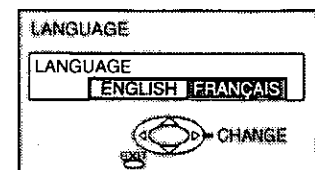
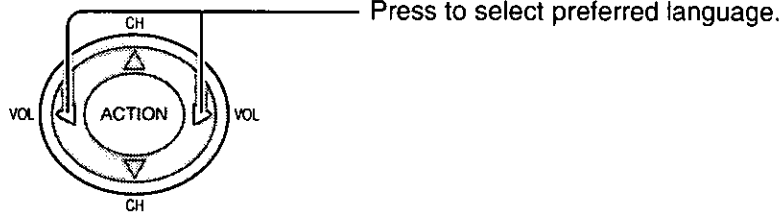

Operating peripheral equipment using the remote control

Programming The Illuminated Remote Control Using Access Codes

The remote control can be preset for other manufacturers, by utilizing the **REMOTE MODE SELECTION BUTTONS** for **CABLE, DTV, VCR, RCVR** (a Receiver or Amplifier), **DVD** (DVD, CD, LD), **DBS** and **AUX** (for **Cassette Player** or a **VCR2**)

(Details on remote control buttons to operate peripheral equipment → See page 61 to 63 and 64 to 66)

1 Setting up the remote using the numerical keys (When the code is known)

1



Press and hold the POWER and ACTION keys simultaneously for three full seconds

After 3 seconds, all the illuminated mode keys will begin to flash

Release the POWER and ACTION keys

+

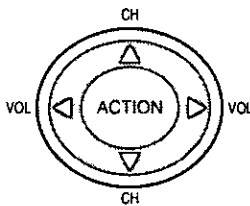

2

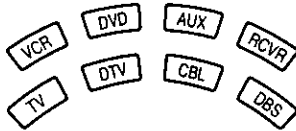

Press the desired mode key

The mode key will illuminate steadily, all others will go out

3

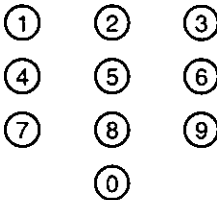

Enter the three digit set up code, by using the Remote Control Keyboard

If the correct code is entered, the mode key will blink twice and then go out

Now your remote is set for this code

Note:

If an incorrect number is entered (or there is an incomplete entry after 30 seconds), the key illumination goes out (no blink) and the settings are unchanged

Device	Operate	Default
TV	TV (Only Panasonic)	Panasonic Code
VCR	VCR (Preset)	Panasonic Code
CBL	Cable Boxes (Preset)	Panasonic Code
DBS	DBS Boxes (Preset)	Panasonic Code
RCVR	RCVR (Preset)	Technics Code
AUX	Cassette Players, VCR2 (Preset)	Technics Cassette Players Code
DVD	DVD & LD & CD Player (Preset)	Panasonic DVD Code
DTV	STB (Only Panasonic)	Panasonic Code

Operating peripheral equipment using the remote control

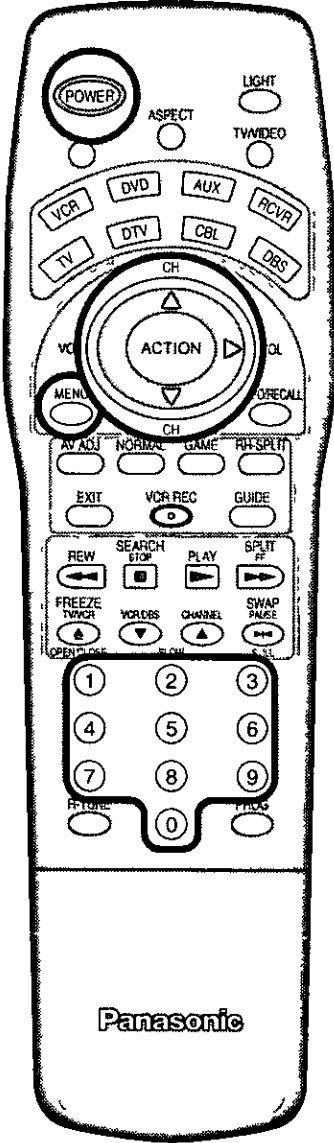

2 Setting to the remote using the step and set method (When the code is not known)

1



Press and hold the POWER and ACTION keys simultaneously for three full seconds
After 3 seconds, all the illuminated mode keys will begin to flash
Release the POWER and ACTION key

+

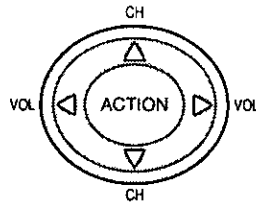

2



Press the mode key
The mode key will illuminate steadily, all others will go out

3

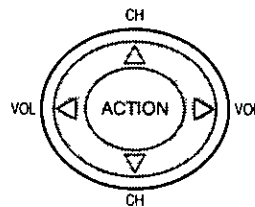

Press VOL "▶" key to step to the next code
Press POWER to send a test signal in that format
Continue doing this until the proper device code is found, and the target device responds

4

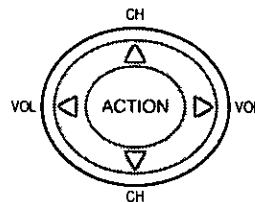

Once the code has been found, press the ACTION key to lock it in

Notes.

- The step and set mode will start from the current device (not the beginning of the list, except for the first time)
- The step and set mode works in the reverse direction using the VOL "◀" key

Infrared Remote Codes for Specific Components

Helpful Hint Write down the code numbers for your components in the space provided below This will serve as a handy reference whenever you need to reprogram your remote control

CABLE Cable Box	<input type="text"/>	VCR Video Cassette Recorder	<input type="text"/>	CD Compact Disc Player	<input type="text"/>
DBS Digital Broadcast System	<input type="text"/>	RCVR Receiver or Amplifier	<input type="text"/>	LD Laser Disc Player	<input type="text"/>
Other Component	<input type="text"/>	Other Component	<input type="text"/>	Other Component	<input type="text"/>
Other Component	<input type="text"/>	Other Component	<input type="text"/>	Other Component	<input type="text"/>

Operating peripheral equipment using the remote control

Infrared Codes Index

The remote control is capable of operating many brands of peripheral equipment. Refer to pages 61 and 62 for programming procedures.

Note: The remote control memory is limited and therefore some models may not operate. The remote control is not designed to control all features available in all models.

Note: After entering the proper infrared code, press the desired Mode Selection Button on the remote control. Refer to pages 16 and 66 to 68, for details on operating peripheral equipment using the remote control.

VCR Infrared Codes Index

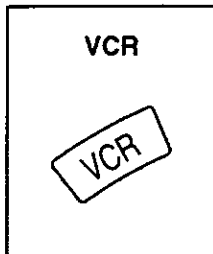

Maker List (VCR)			
Maker	Set Up No.	Maker	Set Up No.
ADMIRAL	200	PENTAX	000, 011, 300
AIWA	137, 160	PHILCO	150, 130, 137, 125 136, 081
AKAI	142, 014, 015, 016	PHILIPS	150, 125, 130
AUDIO DYNAMIC	240, 011	PIONEER	125
BELL & HOWELL	005, 013	PROSCAN	300, 000, 125, 130 150, 310, 001, 002
BROKSONIC	081, 136	QUASAR	100, 101, 125, 130
CANON	125, 135	RADIO SHACK	170, 130, 005, 210 009, 241, 137
CITIZEN	006	RCA	170, 300, 000, 125 130, 150, 310, 001 002
CRAIG	005, 141, 006	REALISTIC	130, 005, 210, 009 241, 137
CURTIS MATHES	300, 130, 137	SAMSUNG	220, 002, 004
DAEWOO	250, 001, 130	SANSUI	240, 136, 081, 520
DBX	240, 010, 011	SANYO	005, 009
DIMENSIA	300	SCOTT	001, 002, 004, 009 230, 241, 330, 340 136, 081
EMERSON	250, 136, 080, 003 135, 243, 081	SEARS	005, 006, 007, 008 000
FISHER	005, 008, 009, 007	SHINTOM	050
FUNAI	137, 136, 081	SHARP	200, 210
GE	170, 300, 130	SIGNATURE 2000	137, 200
GO VIDEO	220, 512	SINGER	050
GOLDSTAR	006	SONY	140, 141, 142
HITACHI	125, 300, 000	SV2000	137
INSTANT REPLAY	130, 125	SYLVANIA	150, 125, 130, 137
JENSEN	240	SYMPHONIC	137
JVC	240, 010, 011, 190	TASHIRO	006
KENWOOD	240, 010, 006, 011	TATUNG	240, 010, 011
LXI	137, 006, 000, 007 008, 005, 009	TEAC	240, 010, 137, 011
MAGNAVOX	150, 125, 130	TECHNICS	100, 101, 125, 130
MARANTZ	240, 010, 011	TEKNIKA	130, 137
MARTA	006	TOSHIBA	001, 310
MEMOREX	130, 009	VECTOR RESEARCH	011
MGA	230, 241, 330, 340 242, 243	WARDS	200, 210, 009, 290 006
MINOLTA	000, 300	YAMAHA	005, 240, 010, 011
MITSUBISHI	230, 241, 330, 340 242, 243	ZENITH	290
MULTITECH	330, 137, 004		
NEC	240, 010, 011, 190		
OLYMPIC	130, 125		
OPTIMUS	140, 100, 200, 006		
ORION	136, 081		
PANASONIC	125, 130, 100, 101		
PENNEY	130, 000, 300, 005, 240, 010, 011		

Operating peripheral equipment using the remote control

CABLE CONVERTER BOX AND DVD, CD, LD PLAYERS Infrared Codes Index

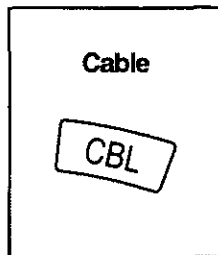

Maker List (CBL)			
Maker	Set Up No	Maker	Set Up No
ABC	530	PULSAR	005, 544
ARCHER	544, 531	PUSER	544
CABLEVIEW	005, 544	REALISTIC	544
CITIZEN	522, 005	REGAL	130, 350, 720, 730
CURTIS	130, 131		731, 900
DIAMOND	530, 544, 531	REGENCY	560
EAGLE	541	REMBRANT	702, 544, 005
EASTERN	560	SAMSUNG	005
GCBRAND	544, 005	SCIENTIFIC ATLANTA	122, 130, 131
GEMINI	522	SLMARK	005, 001
GENERAL INSTRUMENT/JERROLD	360, 530, 531, 532	SPRUCER	005, 121
	533, 520, 521, 522	STARGATE	544, 005
	122	TELEVIEW	001, 005
HAMLIN	720, 730, 731, 900	TEXSCAN	810
	350, 130	TOCOM	700, 701
HITACHI	003, 530	TOSHIBA	004
MACOM	003, 004, 005	UNIKA	544, 531
MEMOREX	542	UNIVERSAL	522, 544
MOVIE TIME	544, 005	VIDEOWAY	006
OAK	710, 702, 002	VIEWSTAR	541, 542
PANASONIC	120, 121, 132	ZENITH	280, 000
PHILIPS	541, 542, 006	ZENITH/DRAKE SATELLITE	000
PIONEER	001, 260		

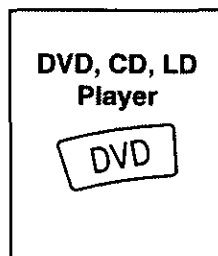

Maker List (DVD)			
Maker	Set Up No	Maker	Set Up No.
DENON	100	RCA	110
FERGUSON	110	SABA	110
NORDMENDE	110	SONY	140
MITSUBISHI	150	THOMSON	110
PANASONIC	100	TOSHIBA	130
PIONEER	120	YAMAHA	100

Maker List (LD)	
Maker	Set Up No
PANASONIC	200, 201, 235, 380
PIONEER	370
SONY	240, 241, 242, 243

Maker List (CD)			
Maker	Set Up No.	Maker	Set Up No
CARVER	550	PHILIPS	550
DENON	600	PIONEER	430
FISHER	405	QUASAR	501, 530, 500
HARMAN/KARON	459, 460, 462	SANYO	405
JVC	590, 591, 670	SHARP	600
KENWOOD	400, 401, 450, 670	SHERWOOD	459
MAGNAVOX	550	SONY	540
MARANTZ	550	TECHNICS	530, 500, 501
MCINTOSH	460	VICTOR	590, 591, 670
OPTIMUS	430, 459	YAMAHA	402, 403, 404
PANASONIC	500, 501, 530		

Operating peripheral equipment using the remote control

CASSETTE PLAYERS, RECEIVERS, AMPLIFIERS, and DBS Infrared Codes Index

**Cassette
Players**

AUX

Maker List (TAPE)			
Maker	Set Up No.	Maker	Set Up No.
PANASONIC	700, 730	TECHNICS	700, 730

**Receiver
Amplifiers**

RCVR

Maker List (RCVR)			
Maker	Set Up No.	Maker	Set Up No.
ADMIRAL	110	PANASONIC	101, 100, 130
AIWA	160, 161	PHILIPS	150
DENON	200, 201, 202	PIONEER	030, 032
FISHER	004	QUASAR	101, 100, 130
GARRARD	055	RCA	003, 030, 162, 171 170
HARMAN / KARDON	057, 150	SANSUI	003, 053, 320
JENSEN	164	SHARP	200, 203
JVC	190, 191	SONY	140
KENWOOD	000, 050	SOUND DESIGN	220
MEGNAVOX	162	TEAC	054, 055, 053
MARANTZ	151	TECHNICS	130, 100, 101
MCINTOSH	058	VICTOR	190, 191
NAKAMICHI	031	YAMAHA	001, 002
ONKYO	051, 056		
OPTIMUS	003, 162, 171, 170		













DBS

DBS

Maker List (DBS)			
Maker	Set Up No.	Maker	Set Up No.
ECHOSTAR	110	PRIMESTAR	391
G.E.	170	RCA	170
HNS (HITACHI)	050	SONY	390
PANASONIC	100	TOSHIBA	000
PHILIPS	001, 002	UNIDEN	001, 002



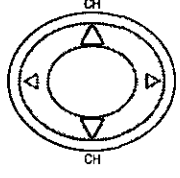







Operating peripheral equipment using the remote control

Remote Control Quick Reference Functional Key Control

KEY	MODE	FUNCTION
① ② ③ ④ ⑤ ⑥ ⑦ ⑧ ⑨ ⑩	TV, DTV, VCR AUX (VCR2) CABLE, DBS RCVR (Receiver/Amplifier)	Select Channel 1 Selects Video 1 2 Selects Video 2 3 Selects Video 3 4 Selects Video 4 5 Selects CD 6 Selects Tuner 7 Selects Phone 8 Selects Tape 9 Selects AUX
	DVD (DVD, CD, LD) TV	Selects Track Number Selects TV Input Mode
	ALL COMPONENTS	Turns On and Off Select Components
	TV, VCR, DBS, DTV CABLE DVD RCVR (Receiver/Amplifier) AUX (Cassette)	Mutes TV Sound Mutes Cable Sound Mutes TV / RCVR Sound Mutes Audio RCVR Mute
	TV	TV Mode Selection for Remote Control
	CABLE	Cable Mode Selection for Remote Control
	DBS	DBS Mode Selection for Remote Control
	VCR	VCR Mode Selection for Remote Control
	Receiver / Amplifier	Receiver / Amplifier Mode Selection for Remote Control
	Digital Video Disc	DVD (DVD, CD, LD) Mode Selection for Remote Control
	Cassette Tape Player, VCR2	AUX Mode Selection for Remote Control Enables User to Operate a Tape Cassette Player, or VCR2
	TV VCR CABLE DBS DVD (DVD) DVD (CD) DVD (LD) RCVR	TV Channel Up/Down VCR Channel Up/Down Channel Up/Down Channel Up/Down, Navigation Up/Down Navigation Up/Down Next Track/Previous Track Next Chapter/Previous Chapter Tuner +/-Tuner -
	TV, VCR CABLE DBS DVD (DVD) DVD (CD) DVD (LD) RCVR	TV Volume Up/Down Cable Volume Up/Down Audio Track +/-, Navigation Right/Left Navigation Right/Left RCVR Volume Up/Down TV Volume Up/Down RCVR Volume Up/Down











Operating peripheral equipment using the remote control

Remote Control Quick Reference Functional Key Control

KEY	MODE	FUNCTION
	TV CABLE DBS DVD (DVD) DVD (CD) DVD (LD) DTV AUX (Tape Cassette Player)	Selects Previously Tuned Channel Selects Previously Tuned Channel Selects Previously Tuned Channel Selects Previous Title Selects Next Disc Side A / B Prev. Ch Selects Tape Cassette Player A or B
	TV CABLE DBS DTV DVD	Activities TV Menus Enter DBS Action STB Action Select
	TV, CBL VCR DBS DTV DVD (DVD) DVD (CD) DVD (LD)	Display Information (Channel, Time, Audio Mode, Power Save Mode) Display Current VCR Settings Display Current DBS Settings Display Current DTV Settings Display Current DVD Settings Display Time format Display Current LD Settings
	VCR DVD (DVD, LD) DVD (CD) RCVR AUX (Tape Cassette Player)	VCR REW Skip Search << Search REW Surround - Tape REW
	TV VCR DVD (DVD, LD) DVD (CD) RCVR AUX (Tape Cassette Player)	SPLIT ON/OFF VCR FF Skip Search >> Search FF Surround + Tape FF
	VCR DVD (DVD, CD, LD) AUX (Tape Cassette Player)	VCR Play Play Tape Play
	TV VCR DVD (DVD, CD, LD) AUX (Tape Cassette Player)	SPLIT Search VCR Stop Stop Tape Stop
	VCR, CABLE DBS DTV AUX (Tape Cassette Player)	VCR Record DBS Record Info (EPG) Tape Record
	TV VCR DVD (DVD, LD) DVD (CD) AUX (Tape Cassette Player)	SPLIT Swap VCR Pause Still Pause Tape Pause
	TV VCR DVD (DVD, CD, LD) AUX (Tape Cassette Player)	SPLIT Freeze TV/VCR Switch Open/Close Tape Open/Close

Operating peripheral equipment using the remote control

Remote Control Quick Reference Functional Key Control

KEY	MODE	FUNCTION
ASPECT 	TV DBS DTV (STB)	TV Aspect DBS Aspect STB Aspect
CHANNEL 	VCR CABLE DBS DVD (DVD) DVD (CD) DVD (LD) RCVR	VCR Channel Up TV Channel Up DBS Channel Up Slow + Repeat LD Side A Center +
VCR/DBS 	VCR CABLE DBS DVD (DVD) DVD (CD) DVD (LD) RCVR	VCR Channel Down TV Channel Down DBS Channel Down Slow - Random LD Side B Center -
AV-ADJ 	TV	AV-Adjust
NORMAL 	TV	NORMAL
GAME 	TV DBS DVD RCVR	Game DBS Page Down Skip - Tuner -
RH-SPLIT 	TV DBS DVD RCVR	RH-SPLIT DBS Page Up Skip + Tuner +
EXIT 	TV DBS DTV (STB)	Exit from Menu Screen DBS Exit Exit (EPG)
PROG 	DBS DTV (STB)	DBS Program STB Program
GUIDE 	DBS DTV (STB)	DBS Guide Guide (EPG)
MENU 	TV DBS DVD (DVD) DVD (CD) DVD (LD) DTV (STB)	TV Menu DBS Menu DVD Menu STB Menu

Troubleshooting

During normal broadcast (VHF/UHF)

Symptoms	Checks	Page
Power does not turn ON	<ul style="list-style-type: none"> ● Is the power plug plugged in? ● If the power does not turn on using the remote, check if the TV set is turned on. 	<p>–</p> <p>17</p>
Remote control does not function	<ul style="list-style-type: none"> ● Are the batteries dead or inserted incorrectly? ● Is the remote control sensor in direct light of florescent lamps or other strong sources of light? 	<p>7</p> <p>–</p>
Image shakes Image is not clear Color patches or no color	<ul style="list-style-type: none"> ● Is the antenna or antenna cable old, broken or shorted? ● Is the antenna cable connected properly? ● When using a VCR and selecting channels on the TV, is the TV/VIDEO mode for the VCR set to TV? 	<p>–</p> <p>8, 9, 10</p> <p>–</p>
Image appears doubled or tripled.	<ul style="list-style-type: none"> ● Is the antenna facing the right direction? ● Is the antenna receiving any signals reflected off mountains or buildings. 	<p>–</p> <p>–</p>
Spots appear in images, images shake, or color patches appear in the four corners.	<ul style="list-style-type: none"> ● Is the TV being affected by geomagnetism or other interference (automobiles and trains, high voltage power lines, neon, motors, magnetic steel frames, steel windows, etc.)? Turn off the power for approx. 20 min. and turn back on or change positioning of the TV set. If this does not fix the problem, the TV needs magnetic shielding. 	<p>–</p>
When the TV set is turned on in a dark room, the outer edges of the screen spark momentarily.	<ul style="list-style-type: none"> ● Due to the internal structure of the CRT set, some parts of the fluorescent components spark, (created by high voltage) when the TV set is turned on. This is not a malfunction. 	<p>–</p>
Unclear or overly bright colors on parts of the screen	<ul style="list-style-type: none"> ● When white is displayed on a certain part of the screen for a while, the white portion tends to tint with color. When the bright image disappears, the screen will return to its normal color. 	<p>–</p>
Left and right ends of the screen, columns and frames appear curved.	<ul style="list-style-type: none"> ● Receiving broadcast or changes in brightness on the screen can cause curves on the screen. 	<p>–</p>
A black stripe appears for a moment when changing channels using the VCR.	<ul style="list-style-type: none"> ● The image distorts when channels are changed. 	<p>–</p>
During Panasonic AUTO mode, the screen size sometimes changes.	<ul style="list-style-type: none"> ● Depending on the program content, even when the screen is supposed to automatically zoom, if the beginning scene is dark, it may take a while for it to zoom. ● During a 4:3 screen, if the top and bottom of the image is dark, it may zoom. 	<p>22, 23</p> <p>–</p>
Images disappear at the top and bottom of the screen	<ul style="list-style-type: none"> ● When using 16:9 image software, there is no picture at the top and bottom of the screen (cinema vision size software, etc.). 	<p>–</p>
During ZOOM or JUST modes, the image is cut off at the top and bottom.	<ul style="list-style-type: none"> ● Has the screen position been changed? → If so, adjust screen positioning. 	<p>32</p>
A clicking and buzzing sound is made when the TV is turned on.	<ul style="list-style-type: none"> ● This is the sound of the Geomagnetic correction function creating a beautiful color picture. This is not a malfunction. 	<p>57</p>

Troubleshooting

During normal broadcast (VHF/UHF)

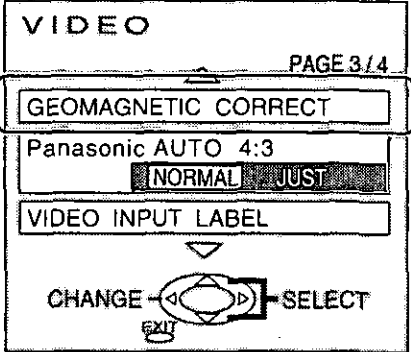
Symptoms	Checks	Page
Image is skewed	<ul style="list-style-type: none"> This could be a geomagnetic effect. (If installed facing south, then image slants down to the right; when facing north, slants down to the left.) Perform geomagnetic correction.  <p>The screenshot shows the TV's menu system. At the top, it says 'VIDEO' and 'PAGE 3/4'. The 'GEOMAGNETIC CORRECT' option is highlighted with a white box. Below it, 'Panasonic AUTO 4:3' is displayed, with 'NORMAL' and 'JUST' options. Further down, 'VIDEO INPUT LABEL' is visible. At the bottom, there are navigation buttons: 'CHANGE', 'EXIT', and 'SELECT'.</p>	57
Channel number remains displayed.	<ul style="list-style-type: none"> Press the INFO/RECALL button. During VIDEO input, channel number is displayed until an image is displayed. 	29
The TV set makes a cracking sound	<ul style="list-style-type: none"> If there are no problems with image or sound, it is the sound of the cabinet shrinking due to room temperature changes. This is not a malfunction. 	-

Specifications

Power Source		AC 120 V, 60 Hz	
Power Consumption		Average use : 177 W (Maximum Current 3.7 A) Stand-by condition : 0.36 W	
CRT		30-inch, 16 : 9 aspect ratio	
Screen Size		25.95 " (659.1 mm) (W) × 14.59 " (370.7 mm) (H) × 29.77 " (756.2 mm) (diagonal)	
Channel Capability-181		VHF-12 : UHF-56 : Cable-125	
Sound	Speaker	5 Speakers	
	Audio Output	21 W [7 W + 7 W + 7 W] (10 % THD)	
	Headphones	M3 (3.5 mm) Jack × 2	
FEATURES		Two screen display fuctions AFB circuit installation CLOSED CAPTION	3D Y/C FILTER 5 Speakers V-Chip
Accessories Supplied		Remote control Transmitter R6 (AA) Battery × 2	EUR511162
Operating Conditions		Temperature : 34 °F - 104 °F (0 ° - 40 °C) Humidity : 20 % - 80 % (non-condensing)	
Connection Terminals		AV INPUT 1- 4	VIDEO (Phono Jack Type) 1.0 Vp-p (75 Ω) S-VIDEO (Mini DIN 4-pin) Y : 1 Vp-p (75 Ω), C : 0.286 Vp-p (75 Ω) AUDIO L-R (Phono Jack Type × 2) 0.5 Vrms
		AV PROG. OUT	VIDEO (Phono Jack Type) 1.0 Vp-p (75 Ω) S-VIDEO (Mini DIN 4-pin) Y : 1 Vp-p (75 Ω), C : 0.286 Vp-p (75 Ω) AUDIO L-R (Phono Jack Type × 2) 0.5 Vrms
		TO AUDIO AMP	AUDIO L-R (Phono Jack Type × 2) 0.5 Vrms
		COMPONENT VIDEO INPUT1-2	Y 1.0 Vp-p (including synchronization) P _B / P _R ± 0.35 Vp-p AUDIO L-R (Phono Jack Type × 2) 0.5 Vrms
Dimensions (W × D × H)		30.6 " (777 mm) × 21.1 " (535.3 mm) × 22.7 " (576 mm)	
Weight (Mass)		128 lb. (58 kg) Net	

Note:

Design and Specifications are subject to change without notice. Weight and Dimensions shown are approximate.

Customer' Record

The model number and serial number of this product can be found on its back cover. You should note this serial number in the space provided below and retain this book, plus your purchase receipt, as a permanent record of your purchase to aid in identification in the event of theft or loss, and for Warranty Service purposes.

Model Number CT-30WX50 Serial Number

**Panasonic Consumer Electronics
Company, Division of Matsushita
Electric Corporation of America**
One Panasonic Way Secaucus
New Jersey 07094

**Panasonic Sales Company,
Division of Matsushita Electric of
Puerto Rico Inc. ("PSC")**
Ave 65 de Infanteria, Km 9 5
San Gabriel Industrial Park,
Carolina, Puerto Rico 00985